



The Ideal Switch[®]

Enabling the electrification of everything:
Milliwatts-to-kilowatts, DC-to-light.

Feb 2026



Menlo Micro Company Overview

The Ideal Switch® is the most revolutionary electronics component invention since the transistor

Company:

- Founded in Dec, 2016
- Irvine, CA (Headquarters);
- Albany, NY (SUNY) (Advanced R&D)
- Employees – 70+ in the US

Capitalization:

- \$228M raised through series C
- Closed series C \$151M Feb 2022

The Ideal Switch® Technology:

- World's smallest, most reliable, most efficient micro-electro-mechanical switch (MEMS) for RF and Power
- Developed over 12+ years at GE Research and 7+ years of commercialization by Menlo Micro
- Ideal Switch 8" wafer manufacturing line in production since Q4 2020

Intellectual Property:

- Fundamental material science-based IP licensed exclusively from GE, 65 patent families

Markets:

- Semiconductor Test, Test & Measurement
- Aerospace and Defense
- Wireless Infrastructure
- Energy Distribution

Our investors

standard
investments

PALADIN

FUTURESHAPE

VERTICAL
VENTURE PARTNERS

PIVA

DBL PARTNERS
DOUBLE BOTTOM LINE VENTURE CAPITAL

Fidelity

Adage

What's new at Menlo Micro:



- 5 years of production on Ideal Switch® 8" manufacturing line. 1M total units shipped through Q2-2025
- 2023 to 2024 YOY \$ growth: **3x increase**, 2024 to 2025 forecast YOY \$ growth: **2x increase**

ideal switch® Gaining Traction!

(10) products now released to production!

- MM5130 (Nov-2020), MM5600 (Nov-2021)
- MM5120, MM5140 (Aug-2022), MM101 (Dec-2022)
- MM5620 (April-2023), MM5622 (Sep-2024)
- MM5230 (Mar-2025), MM5625 (Jun-2025)
- MM5130-NLX (Sep-2025)

Next products to be introduced in 2025:

- RF Products: MM5130-EDC, MM4250
- First Power Products: MM9200 (300V/10A)

Key Product Initiatives for 2026:

- Launch next high frequency product developments
40GHz, 70GHz & 128Gbps loopback relays
- Power Products: MM9200 (300V/10A)

Two types of switches power today's world.

But they're full of compromises.

ELECTROMECHANICAL

RF

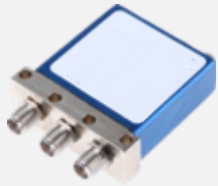

High Power RF Coax
High Isolation
Low Insertion Loss



RF Surface Mount
High Isolation
Low Insertion Loss

POWER



AC/DC Power Relay



**Surface Mount
Signal Relay**

SOLID STATE

RF

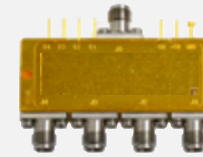

PIN diode
High Power
Fast Switching
Long Life



CMOS
Low Power
Fast Switching
Long Life

POWER



AC/DC SSR w/heatsink
High Voltage
High Current



DC SSR w/heatsink
High Current

The Good: Can handle lots of power

- Metal contacts: low loss and great linearity for RF signals.
- Can handle high power, eg circuit breakers or RF relays.
 - "On" - doesn't generate heat under high currents.
 - "Off" - air-gap open, fully isolated.

The Bad: Big, slow, clunky and expensive

- Moving parts limit switch rate, speed and reliability.
- Manufacturing inconsistencies (some are still assembled by hand).
- Sensitive to mechanical shock, vibration and humidity.

+

-

The Good: Small, fast

- Small size allows for lightweight, tighter packing.
 - Inexpensive to manufacture at scale.
 - Fast, silent switching.
- Immune to mechanical shock, vibration, humidity.

The Bad: It's a semiconductor, not a conductor

- "On" - non-zero losses, generates heat requiring large heatsinks.
 - "Off" - always on, leakage currents, waste power.
- Non-linear effects of transistor distorts RF signal integrity.

Introducing the Ideal Switch™

*Technology platform with
breakthrough innovations
in materials and processing*

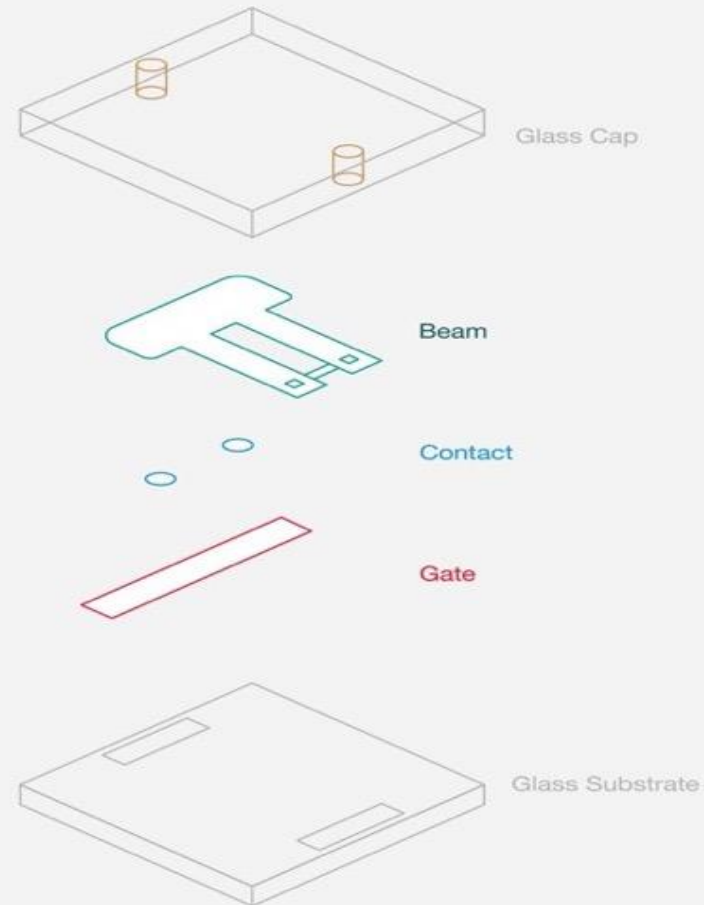
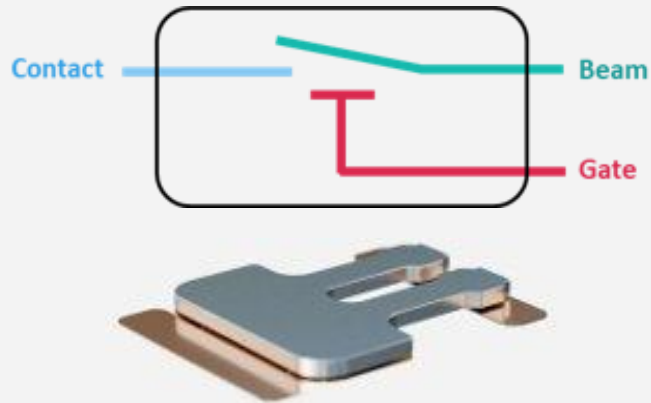

Unique Glass Packaging

Improved RF & thermal performances
High RF power handling

Through-Glass-Via

Low parasitics and resistance
Small-size package

High Reliability

>3B switching cycles
Hermetic-sealed package

Scalability

100 μ m x 100 μ m (unit cell)
Scalable switch arrays for high
voltage, high current, high power

The Beam

Smaller than a human hair, can handle >400 V

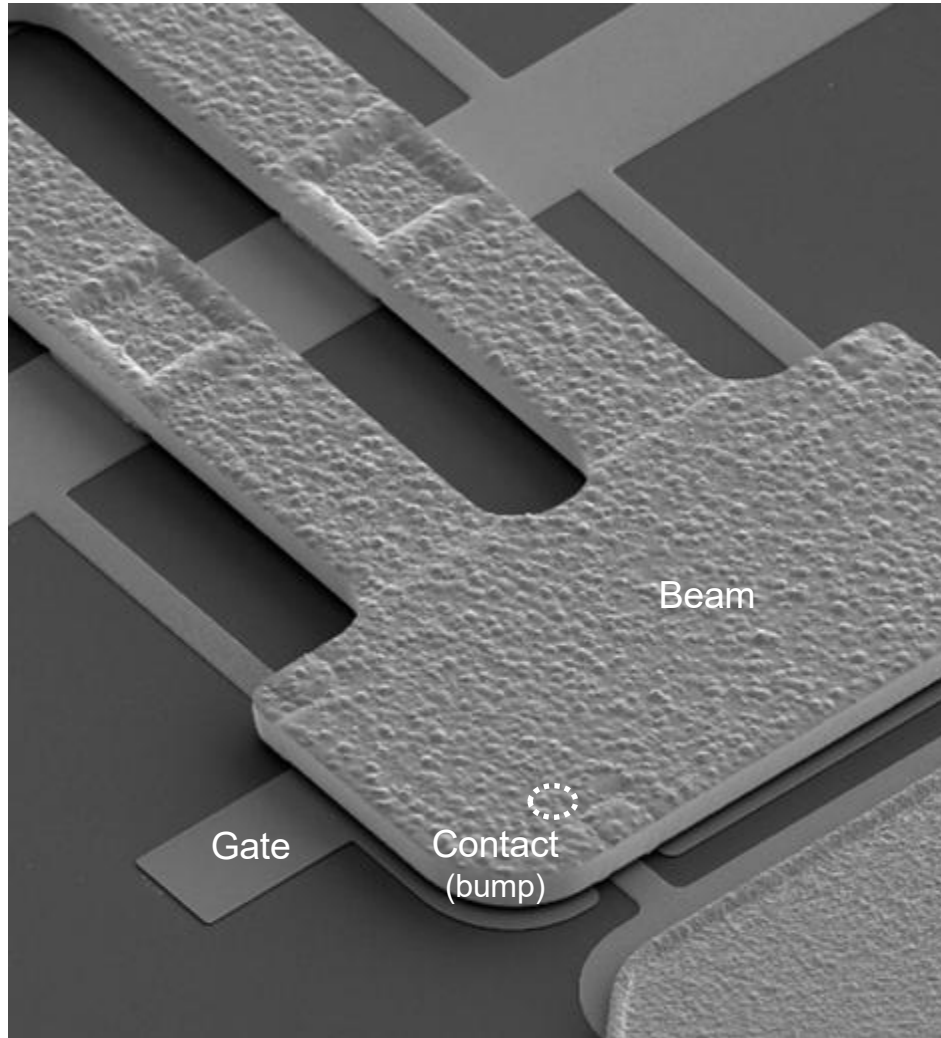

System-In-Glass Packaging

Close-up view of Through-Glass-Vias and hermetically sealed package

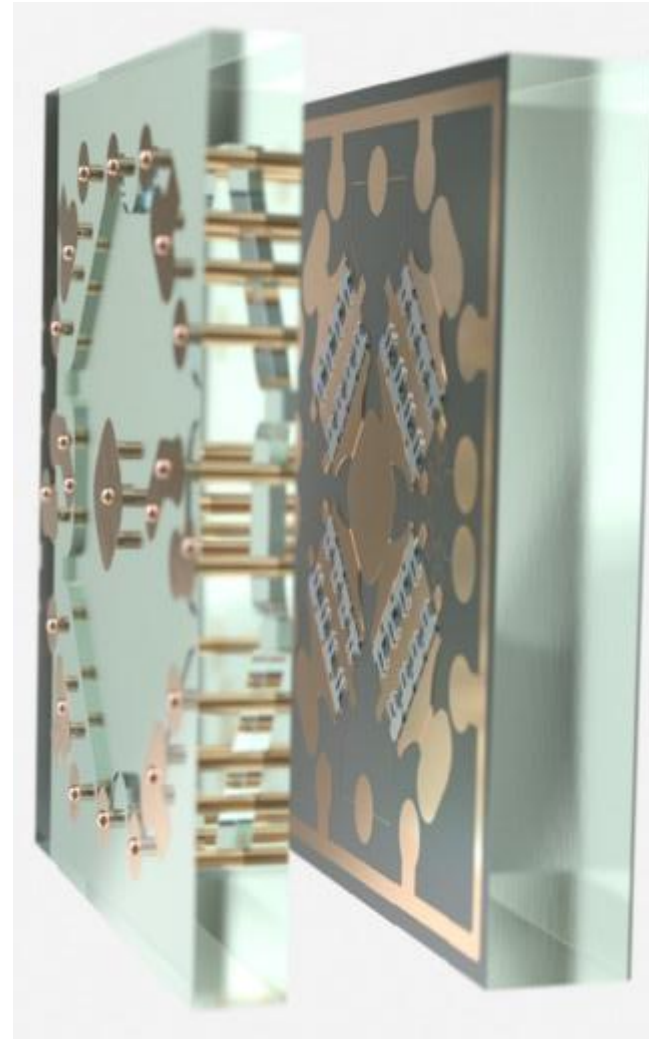

Product Portfolio – RF & Microwave Products



	RF & Microwave			
	MM5230	MM5130-EDC	MM5120	MM5140
Markets	Telecommunication, Wireless Systems, Aerospace & Defense, Test & Measurement			
Applications	Tunable & Programmable Filters, High-Power Low-Loss RF Switch Matrices, Programmable RF Beam Steering			
Switch Type	SP4T			
Frequency Range	DC – 26 GHz		DC – 18 GHz	DC – 8 GHz
RF Power	25 W (CW), 150 W (pulsed)			
Insertion Loss	0.3 dB @ 6 GHz		0.4 dB @ 6 GHz	0.3 dB @ 3 GHz
Linearity (IP3)	>90 dBm			
Control	Direct HV		SPI/GPIO	SPI/GPIO
DC Supply	89 V (gate)		3.3 V (ctrl), 5 V (V _{CP})	3.3 V (ctrl), 5 V (V _{CP})
Lifetime	>3B cycles			
Package	2.5 mm x 2.5 mm 21-pin WLCSP	2.5 mm x 2.5 mm 29-pin WLCSP	5.2 mm x 4.2 mm LGA	
Operating Temp	-40C to 85C		-40C to 125C	
Availability	In production		Samples: Available Prod: Q4 2025	In production

Product Portfolio – High-Speed Products



	High-Speed Digital			
	MM5600	MM5620	MM5622	MM5625
Markets	Semiconductor Test & Measurement, Automated Test Equipment, Aerospace & Defense Equipment			
Applications	High-Speed Digital SoC Loopback Testing, PCIe Gen6, DDR5, MIPI, USB-C, High-Speed Ethernet, etc			
Switch Type	DPDT	2x DP3T Diff AC Coupled	2x DP3T Diff DC Coupled	2x DP3T Diff AC Coupled
Max Data Rate PAM4	40 Gbps	64 Gbps	80 Gbps	80 Gbps+
Insertion Loss	1.3 dB @ 10 GHz	1.5 dB @ 16 GHz		1.1 dB @ 16 GHz
Control	Serial to Parallel	SPI/GPIO		
DC Supply	5 V (control), 89 V (gate)	3.3 V (control), 5 V (V_{CP})		
Lifetime	> 3B cycles			
Package	8 mm x 8 mm LGA	8.2 mm x 8.2 mm LGA		
Operating Temp	-40C to 85C			
Availability	In production			

Product Portfolio – Drivers & Power

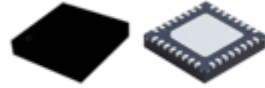

	Drivers	Power Chip	Power Module
	MM101	MM92xx	DC Module xx
Markets	All	Hi-Rel, Data Center, Industrial Automation	Hi-Rel, Data Center, Industrial Automation
Applications	All	Replacement for Electro-Mechanical relays, contactors and circuit breakers	Replacement for Electro-Mechanical relays, contactors and circuit breakers
Switch Type	High voltage CP + 8-channel driver	SPST	SPST
DC Current		15 A (AC or DC), 10 mΩ*	30A, 15 mΩ*
DC Carry/Standoff Voltage	---	400 V (AC or DC)*	800 VDC
Control	SPI/GPIO	Direct	Direct
DC Supply	3.3 V (control), 5 V (V _{CP})	90 V (gate)	90V
Lifetime	---	>100M cycles	>10M cycles
Package	5 mm x 5 mm QFN 1.6 mm x 2.4 mm WLCSP	5 mm x 5 mm WLCSP	14 pin 40 x 30 mm*
Operating Temp	-40C to 85C		
Availability	In production	Engr. Samples: Q2, 2027 Production: Q4 2027	Engr. Samples: Q1, 2027

Website Resources – The Menlo Support Portal

Additional product support/documentation can be found by logging in through Menlo’s website <http://www.menlomicro.com/>

- Users can sign up by clicking on “Login” and then “Request Access”
- Access is typically granted within 24hrs

The screenshot displays the Menlo Micro website homepage. At the top, a dark blue banner reads "MENLO MICRO WELCOMES UNDER SECRETARY OF DEFENSE, HEIDI SHYU, TO IRVINE, CALIFORNIA HEADQUARTERS" with a link to "READ THE PRESS RELEASE. >". The main navigation bar includes the Menlo Micro logo, "TECHNOLOGY", "MARKETS", "PRODUCTS", "COMPANY", "NEWS", a "LOGIN" button (highlighted with a red box), and a "BUY NOW" button. A search icon is also present. Below the navigation, the main content area features the "ideal switch" logo and the headline "Introducing the next generation of electrification." Below this, a paragraph states: "Over 40 years of innovation and unprecedented collaboration among industry pioneers have finally achieved the Holy Grail of electronics." A "Contact us" button with a chat icon is located in the bottom right corner. A light blue modal window is overlaid on the right side, containing the "menlo support portal" logo, an "Email*" input field, a "Password*" input field, a "Forgot?" link, and "LOGIN" and "REQUEST ACCESS" buttons. The modal is also highlighted with a red border.

Website Resources – The Menlo Support Portal

Each Series consists of the following where you can find:

- Product Briefs
- Application Notes
- Qualification Reports
- S-Parameters
- Transmission Line Models
- CAD Drawings
- Assembly Instructions
- RoHS/REACH Certificates
- Eval Board GUI
- Eval Board Instructions
- Video Tutorials
- FAQs
- Product Images

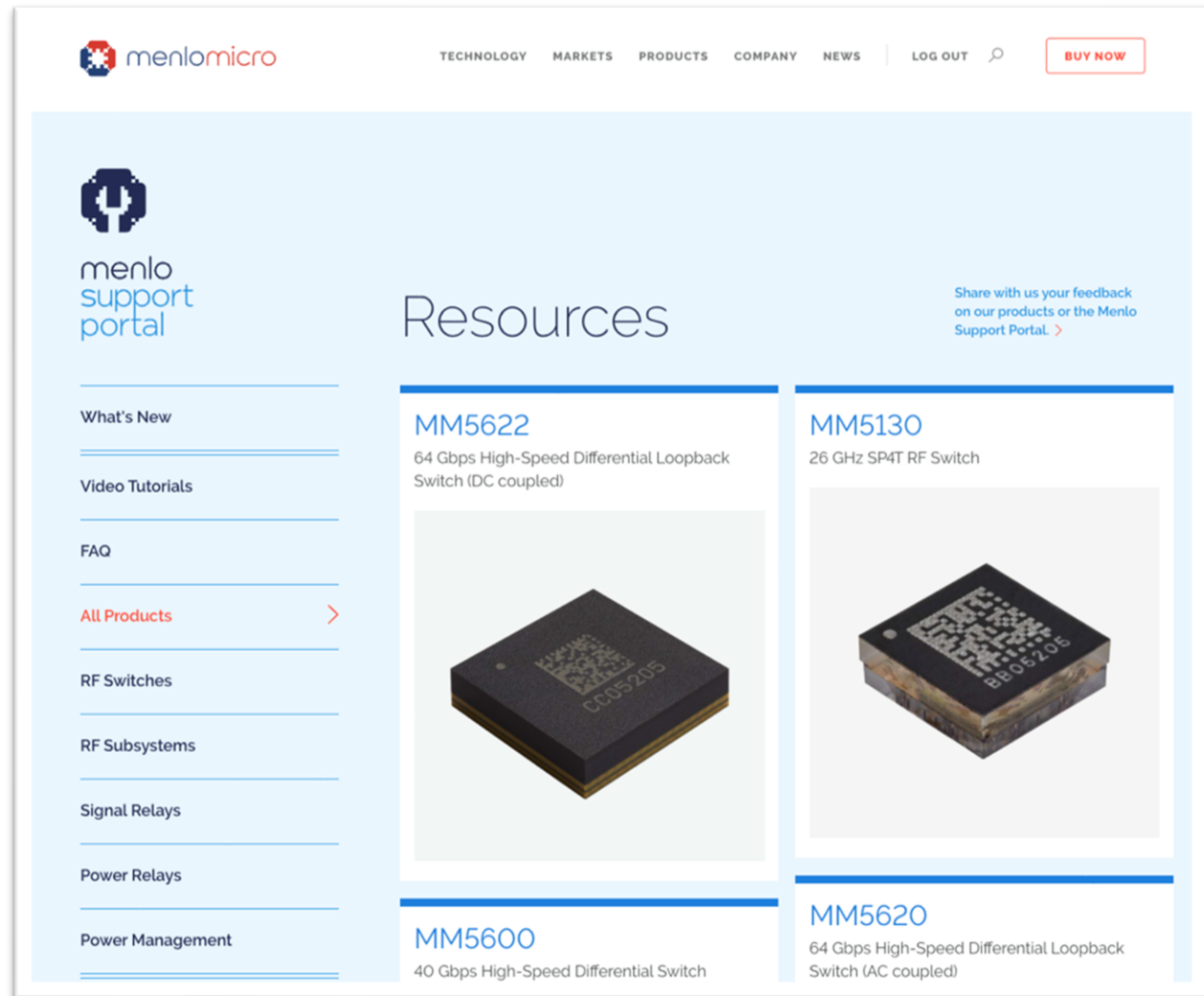

The screenshot displays the Menlo Support Portal website. At the top, the Menlo Micro logo is on the left, and navigation links for TECHNOLOGY, MARKETS, PRODUCTS, COMPANY, NEWS, LOG OUT, and a BUY NOW button are on the right. The main content area features a 'Resources' section with a sidebar menu on the left and product cards on the right. The sidebar menu includes: What's New, Video Tutorials, FAQ, All Products (highlighted with a red arrow), RF Switches, RF Subsystems, Signal Relays, Power Relays, and Power Management. The 'Resources' section contains three product cards: MM5622 (64 Gbps High-Speed Differential Loopback Switch (DC coupled)), MM5130 (26 GHz SP4T RF Switch), and MM5620 (64 Gbps High-Speed Differential Loopback Switch (AC coupled)). Each card includes a 3D image of the component. A feedback link is also visible in the top right of the resources section.

MM5230

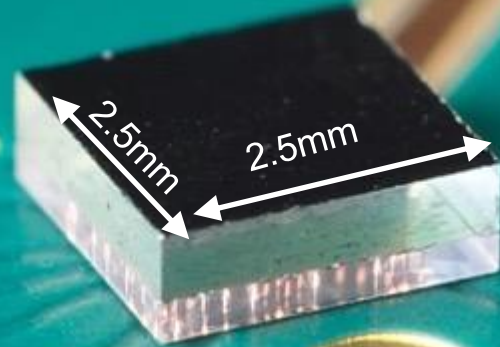

World's smallest, high power SP4T in SMT package
25W per channel, DC-26GHz operation

MM5230 – Product Highlights

- **Switch Type:** SP3T (Super-Port), SP4T (Standard)
- **Frequency:** DC to 26 GHz (Super-Port)
- **Insertion Loss:** 0.8 dB @ 18 GHz (Super-Port)
- **Isolation:** 28 dB @ 18 GHz (Super-Port)
- **RF Power:** 25 W (CW) @ 6 GHz, 150 W (pulse)
- **IP3:** 95 dBm
- **Actuation Voltage:** 89 V
- **Reliability:** 3B switching cycles guarantee
- **Package:** 2.5 mm x 2.5 mm x 0.9mm WLCSP (BGA)

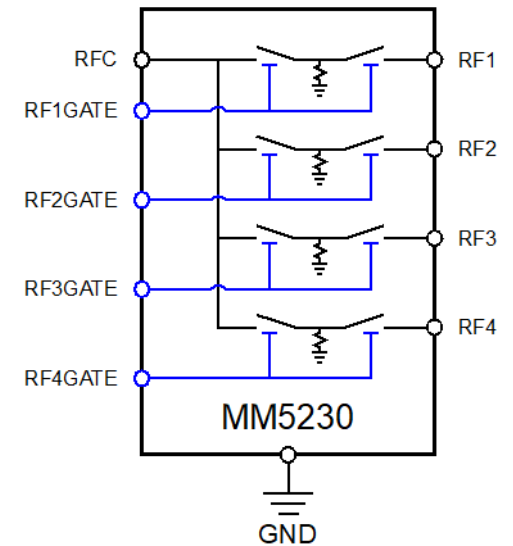
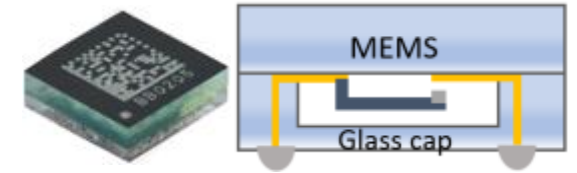

MM5130 – Product Enhancements – MM5230

MM5230 has same RF specs as MM5130, easier to assemble package

MM5130

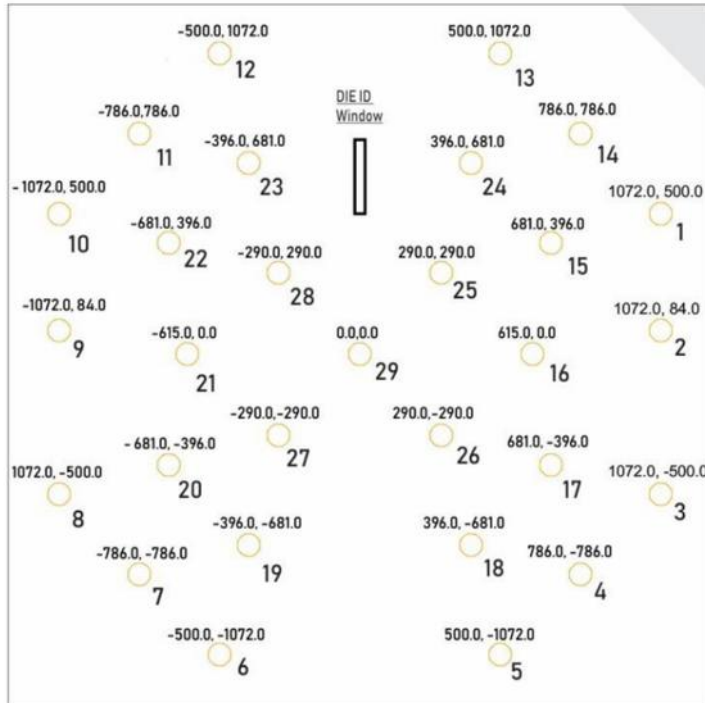



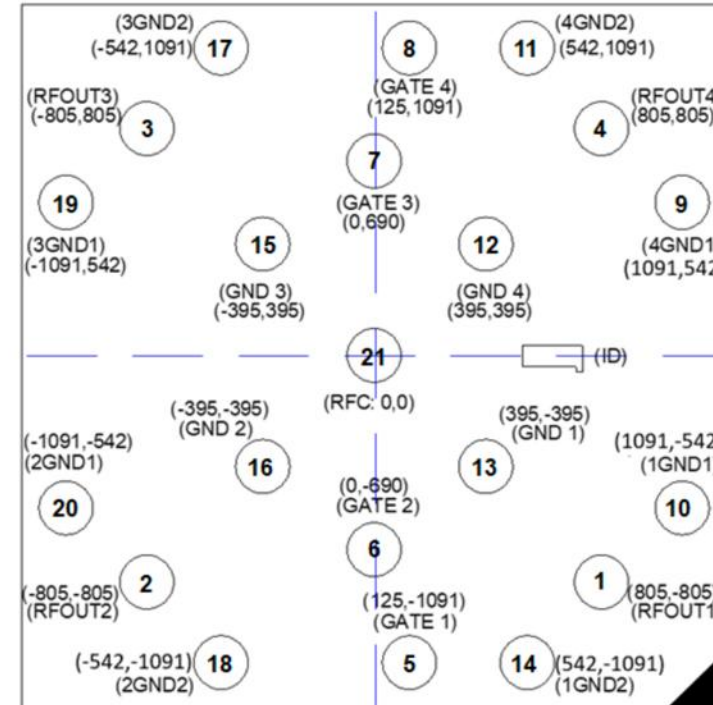

29-pin WLCSP, 100um Cu pillar

MM5230



21-pin WLCSP, 200um solder ball, easier assembly

MM5230 vs. Electromechanical RF Relays



	  MM5230 SP4T WLCSP	 EM (SMT) SPDT	 EM (coax) SPDT	
Max Frequency	26GHz	6GHz	18GHz	
Insertion Loss	0.3dB @ 6GHz	0.8dB @ 6GHz	0.2dB @ 6GHz	
Isolation	>30dB @ 6GHz	25dB	70dB	
Power Handling	25W (CW) >150W (pulsed)	50W	50W-100W	
Linearity (IP3)	95 dBm	62dBm		
Power Consumption	<0.08mW	140mW	5000mW	94%–99% Reduction
Reliability	>3B operations	10M	1-5M	> 1000X Improvement
Switching speed	<10us	3-5ms	10-20ms	> 1000X Improvement
Size/Ch. Density	5.6 mm ³ 2.5 x 2.5 x 0.9 mm WLCSP	1280mm ³ 16 x 8 x 10 mm SMT	30,000mm ³ 50 x 50 x 12 mm COAX	>99% Reduction

Ideal Switch Provides:

Power handling & RF performance of EM relay

Size, weight, reliability, and speed of solid-state

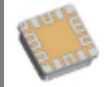
MM5230 vs. PIN & GaN

	 MM5230 SP4T WLCSP	 GaN (SMT) SPDT	 PIN (SMT) SP4T	
Max Frequency	26GHz	12GHz	26GHz	
Isolation	>30dB @ 6GHz	40dB @ 6Ghz	42dB @ 6Ghz	
Power Handling	25W (CW) >150W (pulsed)	20W	6.3W	
Linearity (IP3)	95 dBm	62dBm	60dBm	1000 x Improvement
DC Capable	Yes	No	No	
Insertion Loss	0.3dB @ 6GHz 0.75dB @ 12Ghz	0.8dB @ 6GHz 1.5dB @ 12Ghz	0.6/1.9dB @ 6GHz (w/o & w/bias-tee)	
Power Consumption	<0.08mW	0.1mA @ 40V, 10mW	20mA @ -15V 660mW total	Up to 99% Reduction
Reliability	>3B operations	Unlimited operations	Unlimited operations	
Switching speed	<10us	35nS	20ns	

Ideal Switch Provides:

- Highest power density (SP4T 25W power handling)
- Best Linearity/Harmonics
- Lowest RF insertion loss
- Ultra-low power consumption

MM5230 Super-Port Mode

- Bypass the RFC connection, connect any of the remaining 4 channels to any other channel
- SP3T with improved broadband performance out to 26 GHz

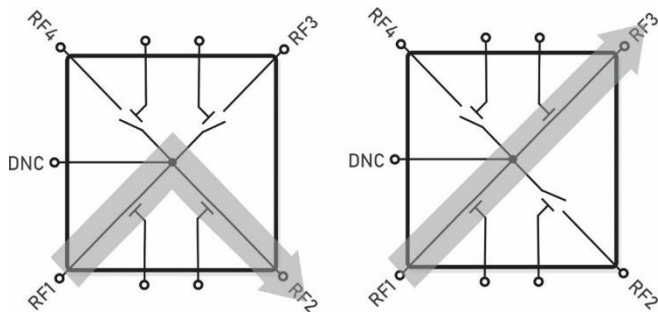

Adjacent
 RF1-RF2
 RF2-RF3
 RF3-RF4
 RF4-RF1

Non-Adjacent
 RF1-RF3
 RF2-RF4

Insertion Loss

Measured at 25C, Data is De-Embedded

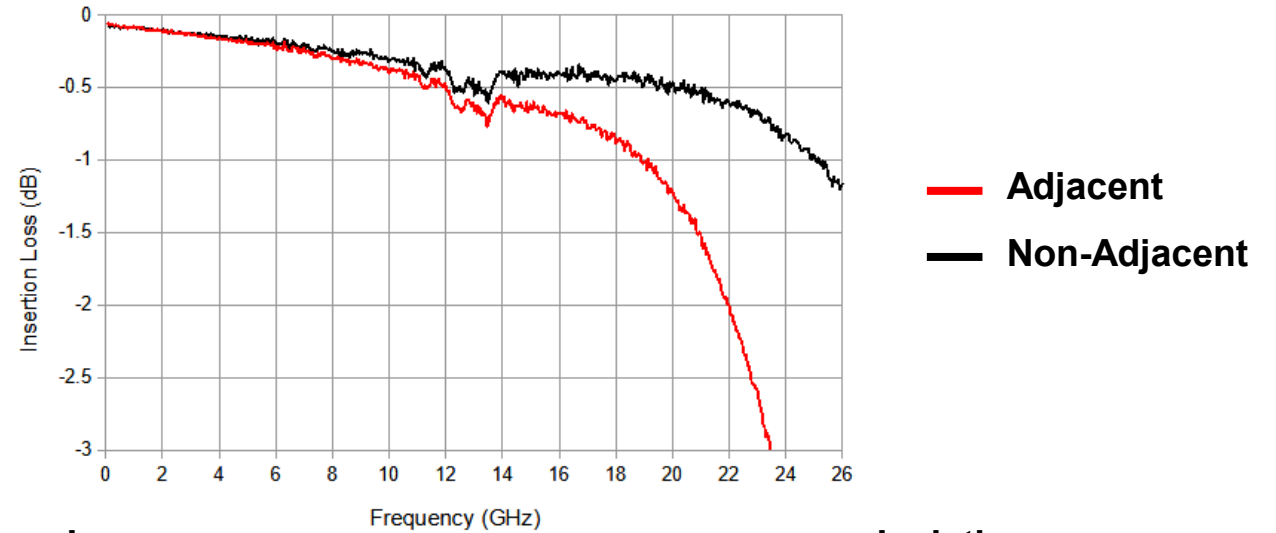

Return Loss

Measured at 25C, Data is De-Embedded

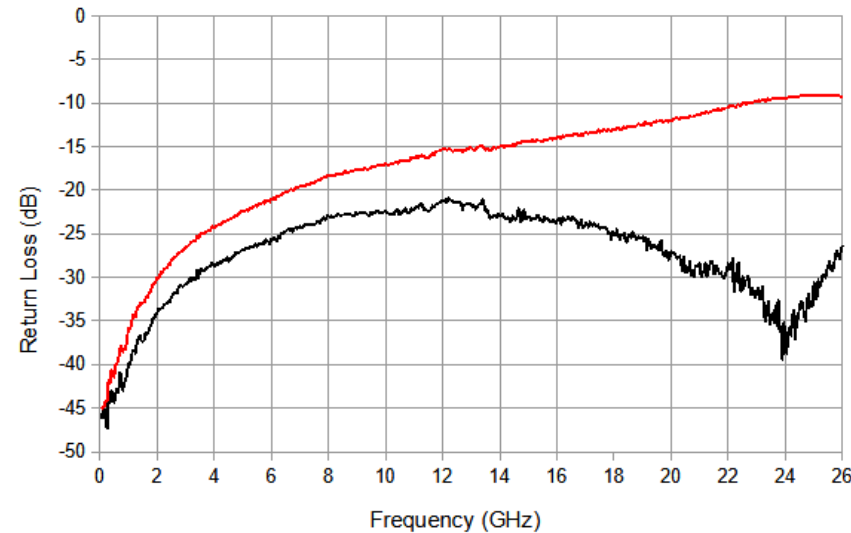

Isolation

Measured at 25C, Data is De-Embedded

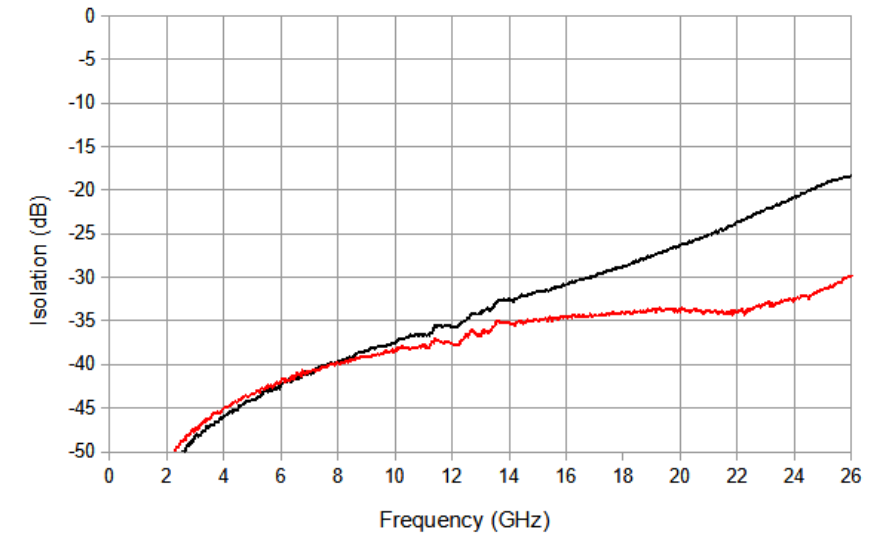

MM5230 – CH. To CH. Variation

MM5230



25W SP4T
DC to 18GHz+
2.5mm x 2.5mm
WL-Flip-Chip
package

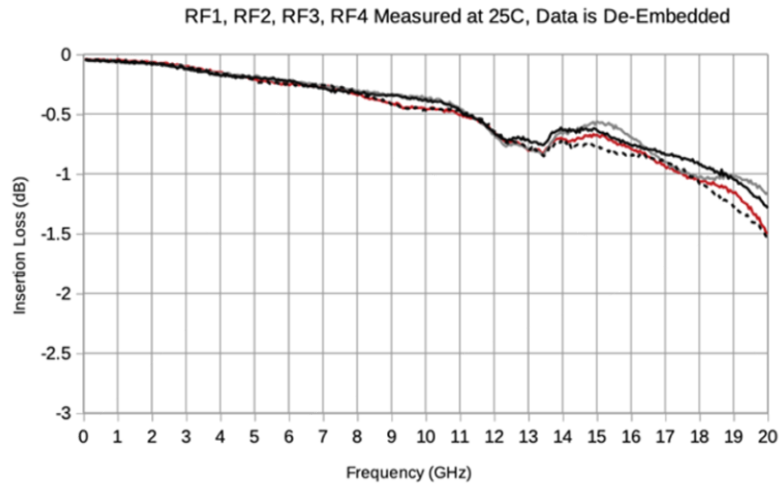

Figure 6. Insertion Loss / S21

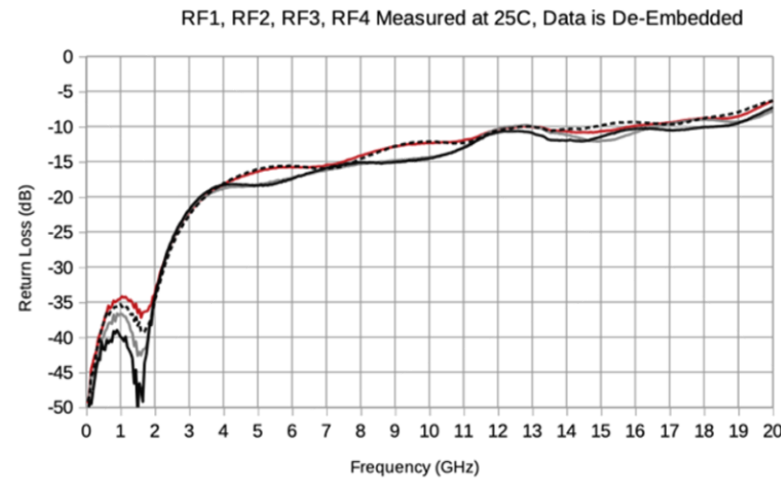

Figure 7. Return Loss / S11

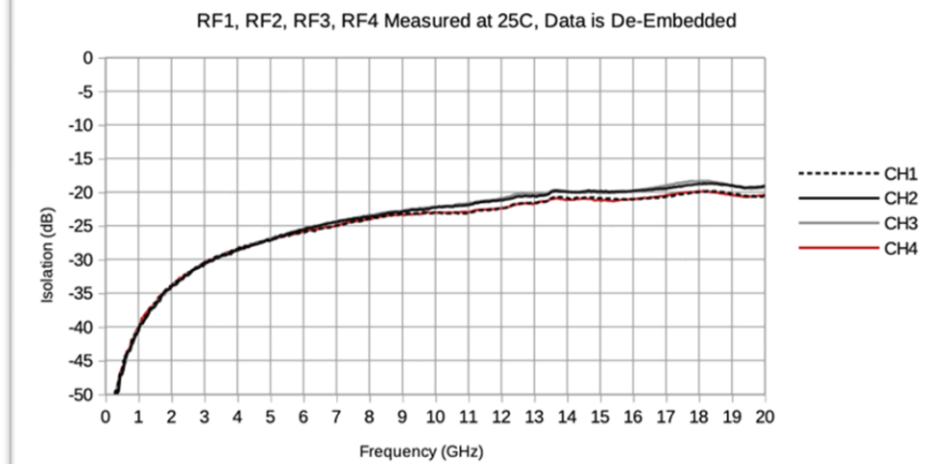

Figure 8. Off-State Isolation / S21

MM5230 EVK



- Measurements taken on Keysight M9375A VNA
- PCB and connectors deembedded using Keysight AFR method:

<http://literature.cdn.keysight.com/litweb/pdf/5992-0656EN.pdf>

Metal-on-Glass for Highest Linearity

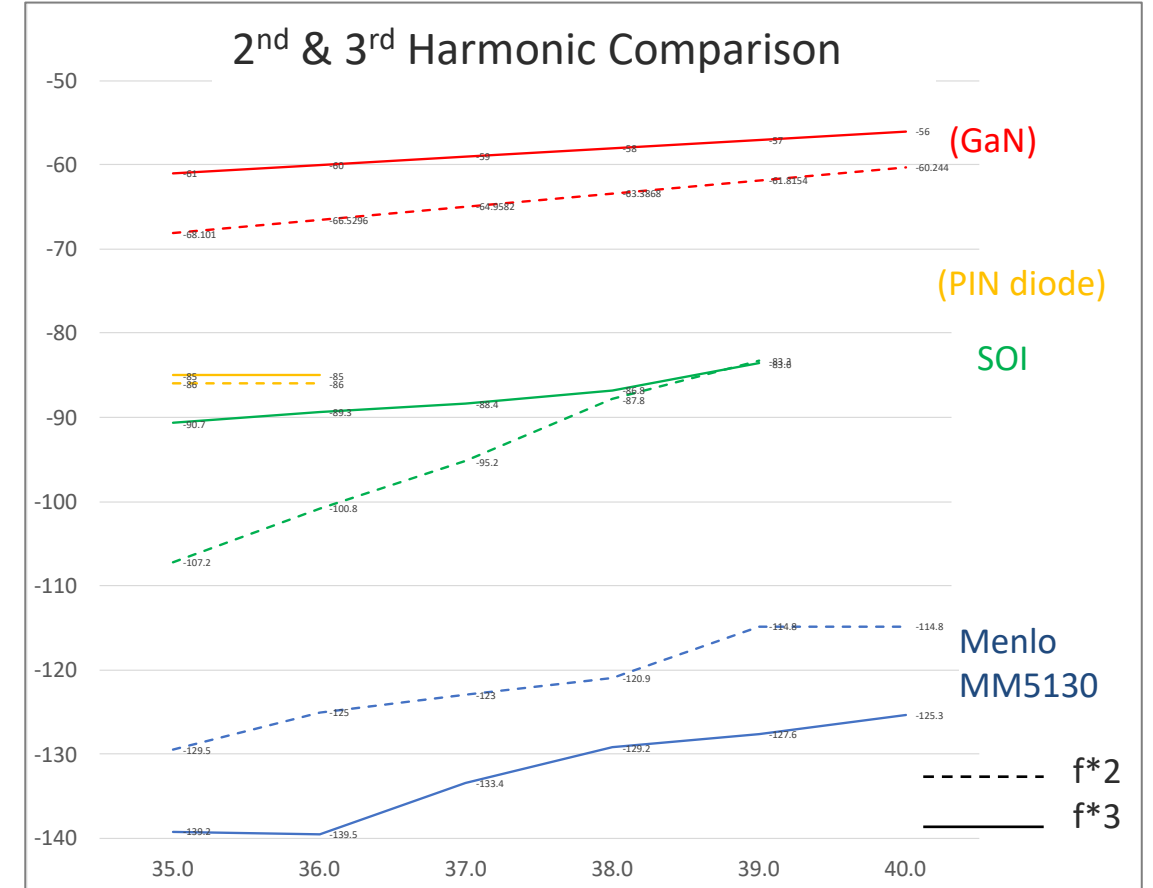
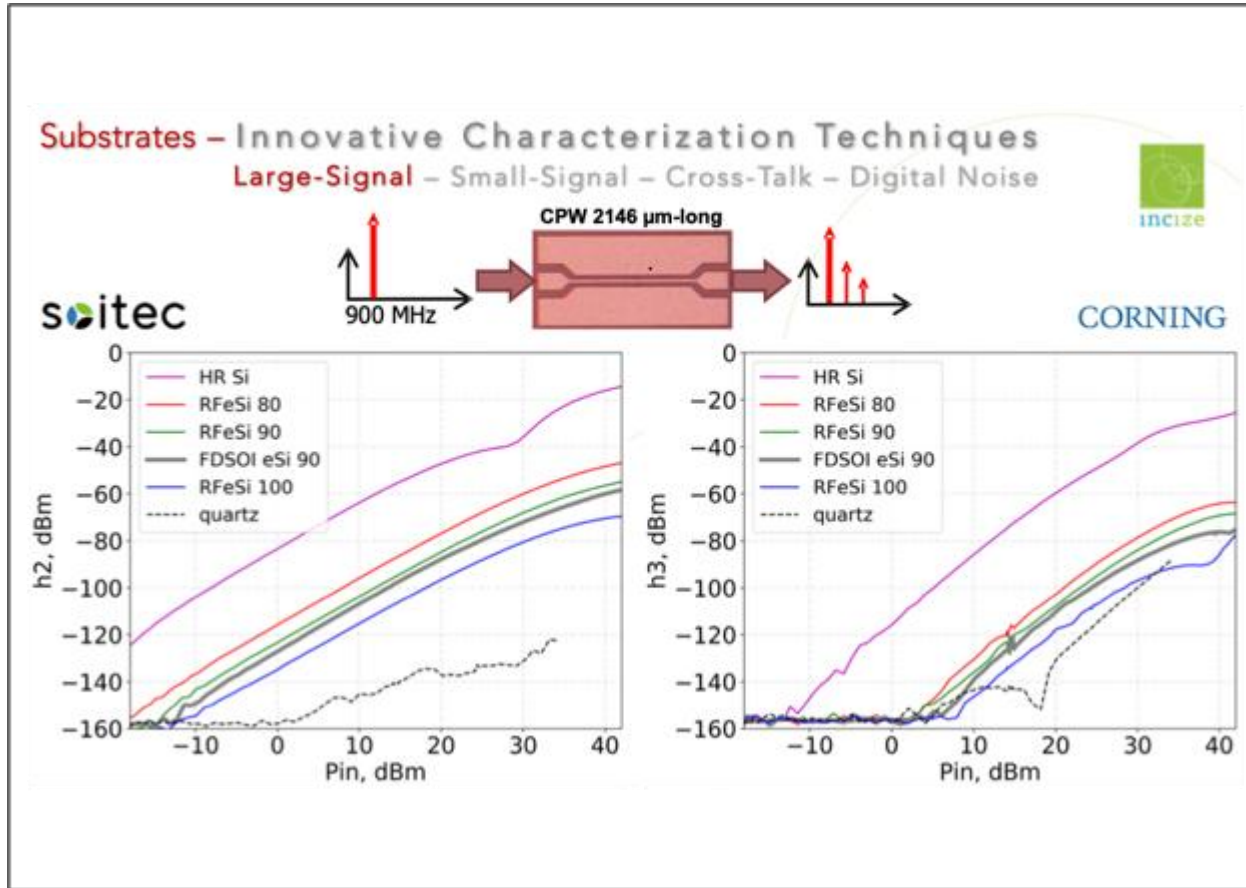

Moving from silicon to glass and removing the transistor from the RF signal chain helps reduce many sources of non-linearity.

Ideal Switch for Cryo – MM4250

Ultra-Low Power SP6T Switch Module for Quantum Computing

- ❖ RF switching to 10mK, compatible with existing dilution fridge connectivity
- ❖ Extremely low activation power to eliminate heating. Speeds measurements and avoids damaging sensitive electronics
- ❖ Built-in internal RF calibration standards.



MM4250

Ease of adoption/integration into existing fridge RF measurements

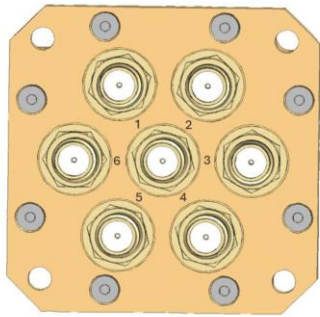
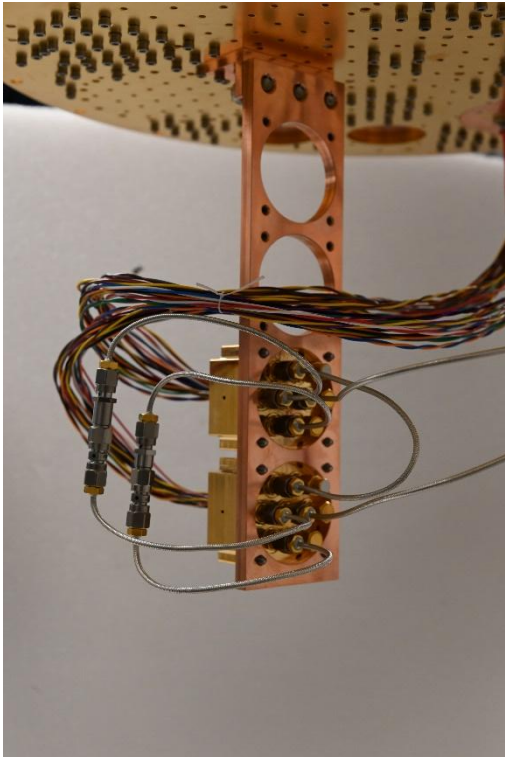
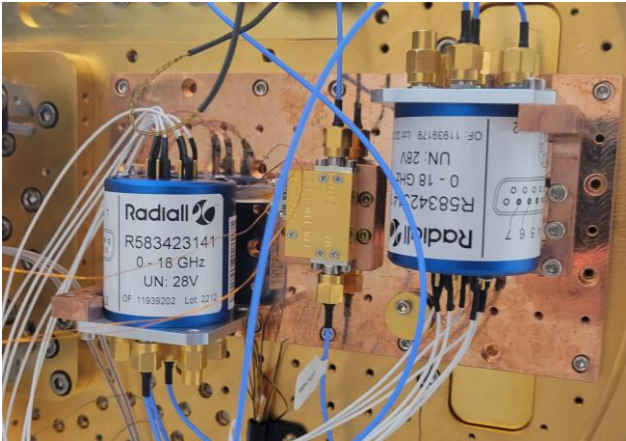

MM4250 intended to be “mounting plate compatible”

Superior Environmental Performance Temperature **COLD**

Ideal Switch can also operate at extreme cold temperatures!

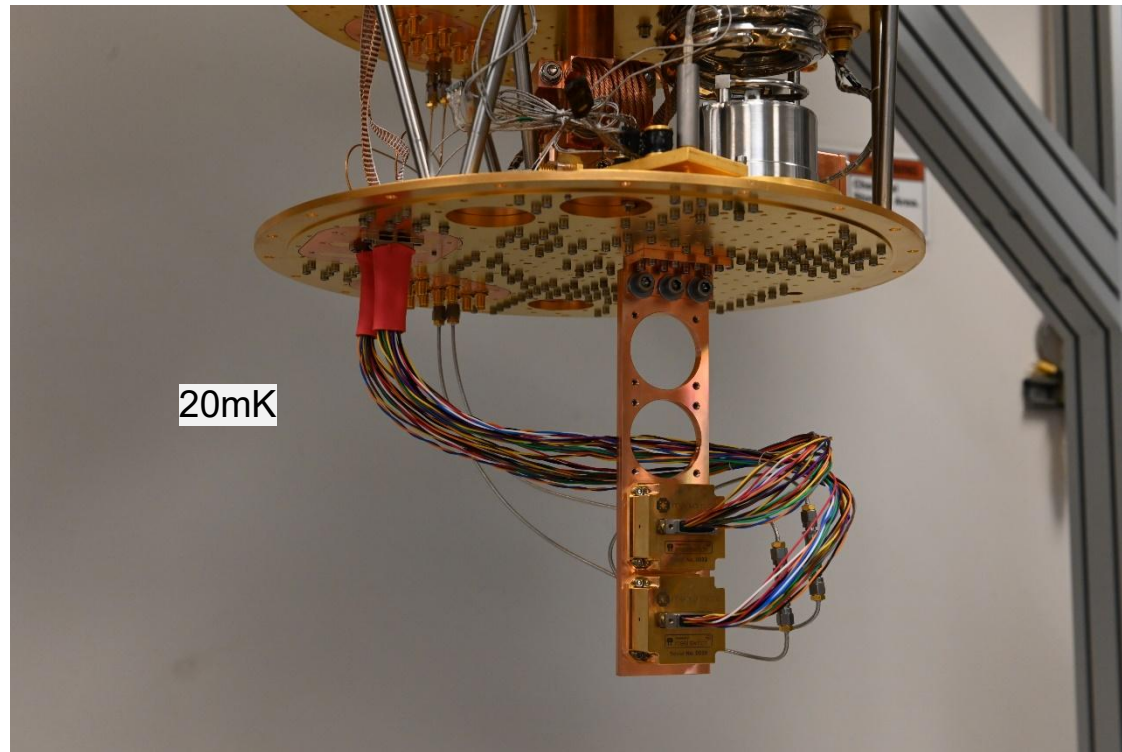

Testing performed at

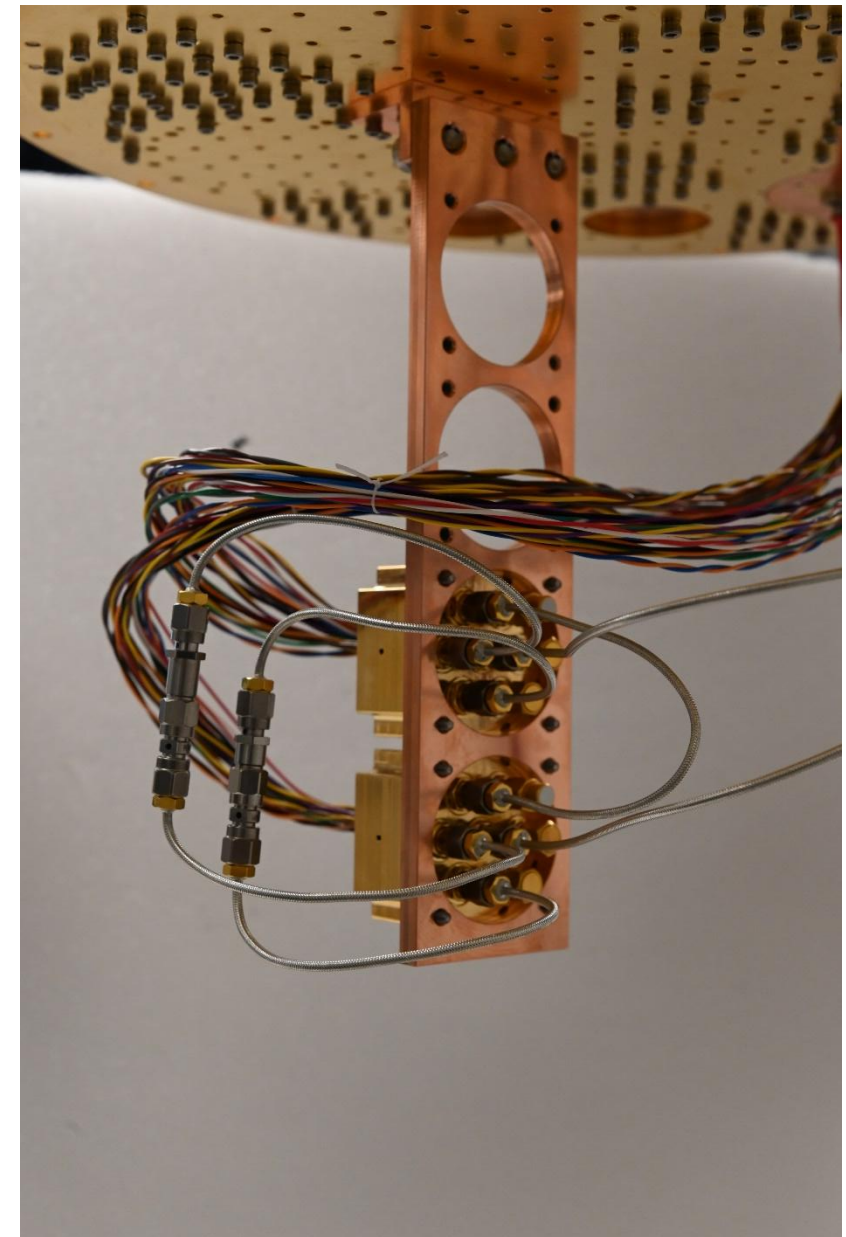

MM4250 Performance

Ambient Temp; Common to RF Channel Measurements

Insertion Loss

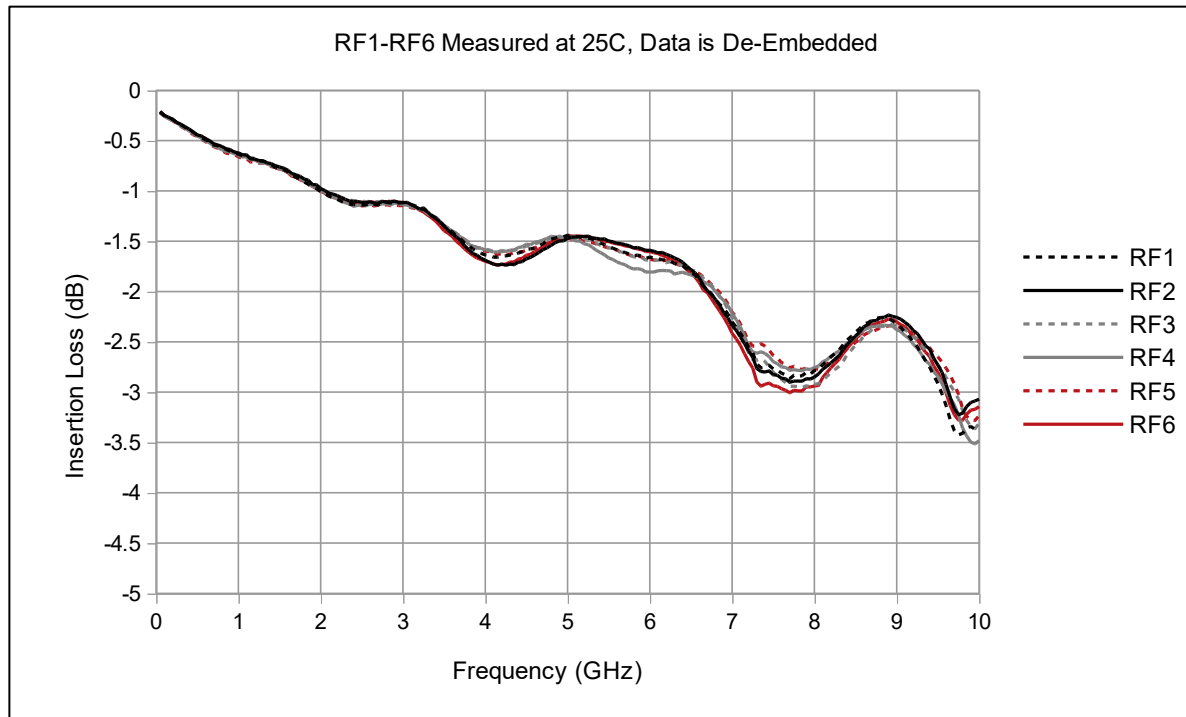

Isolation

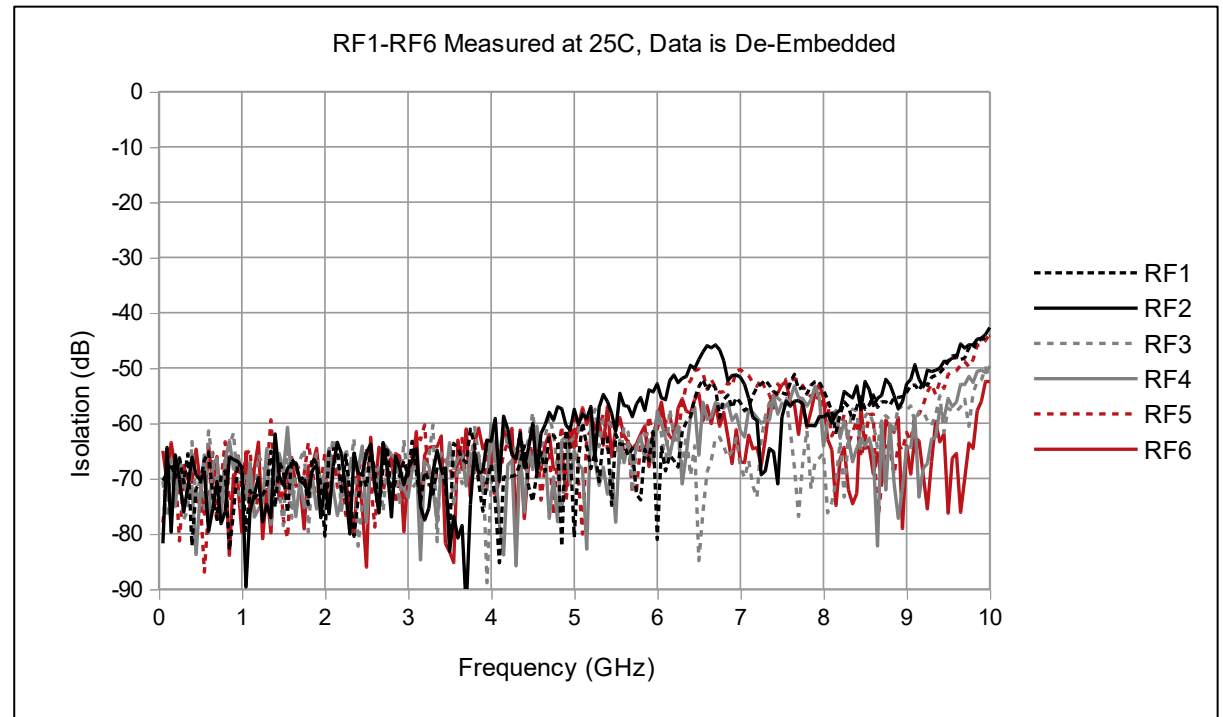

Preliminary Measurements

MM4250 Performance

Room vs **Cold** Temperature Measurements

Insertion Loss

Measured at 295K and 3K

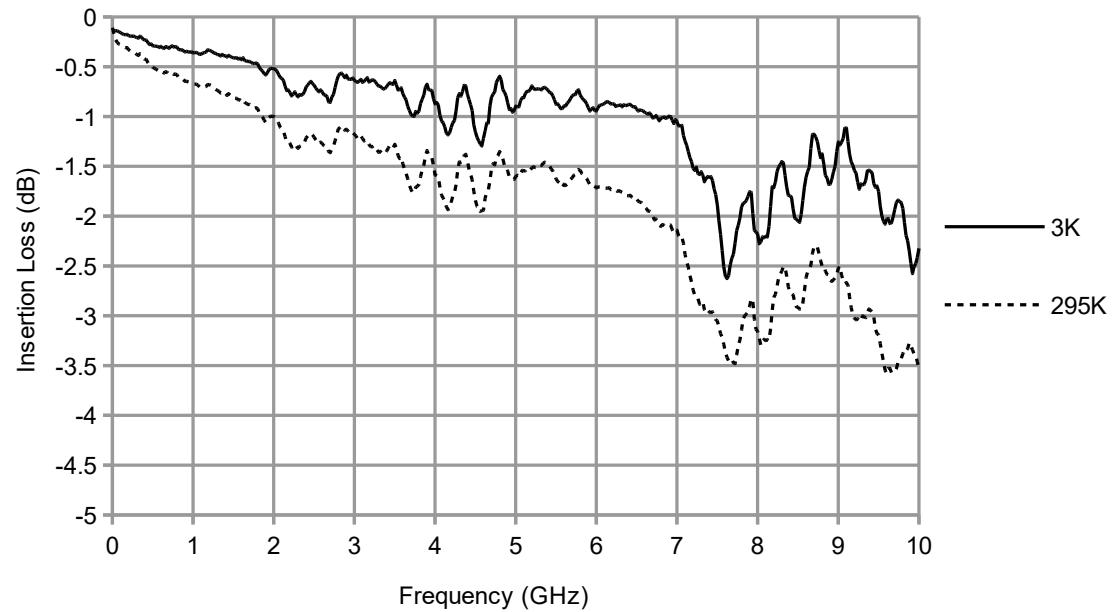

Isolation

Measured at 295K and 3K

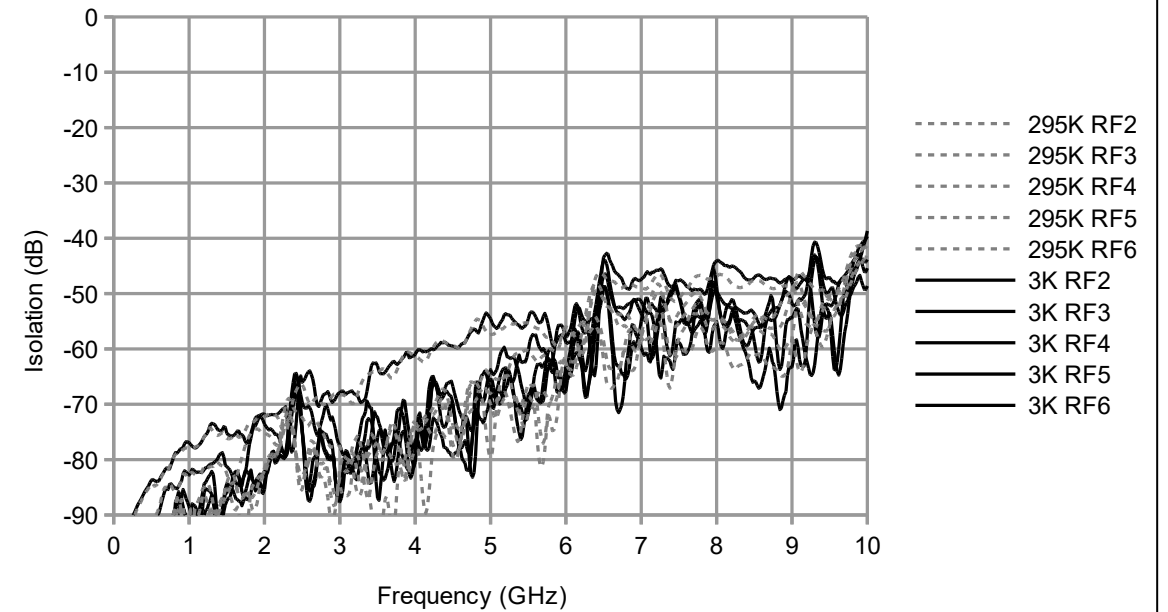

MM4250 Cycling Performance

Cold Temperature Cycling Measurements

Before and After 235,800 Cycles @ 1 Hz

Insertion Loss

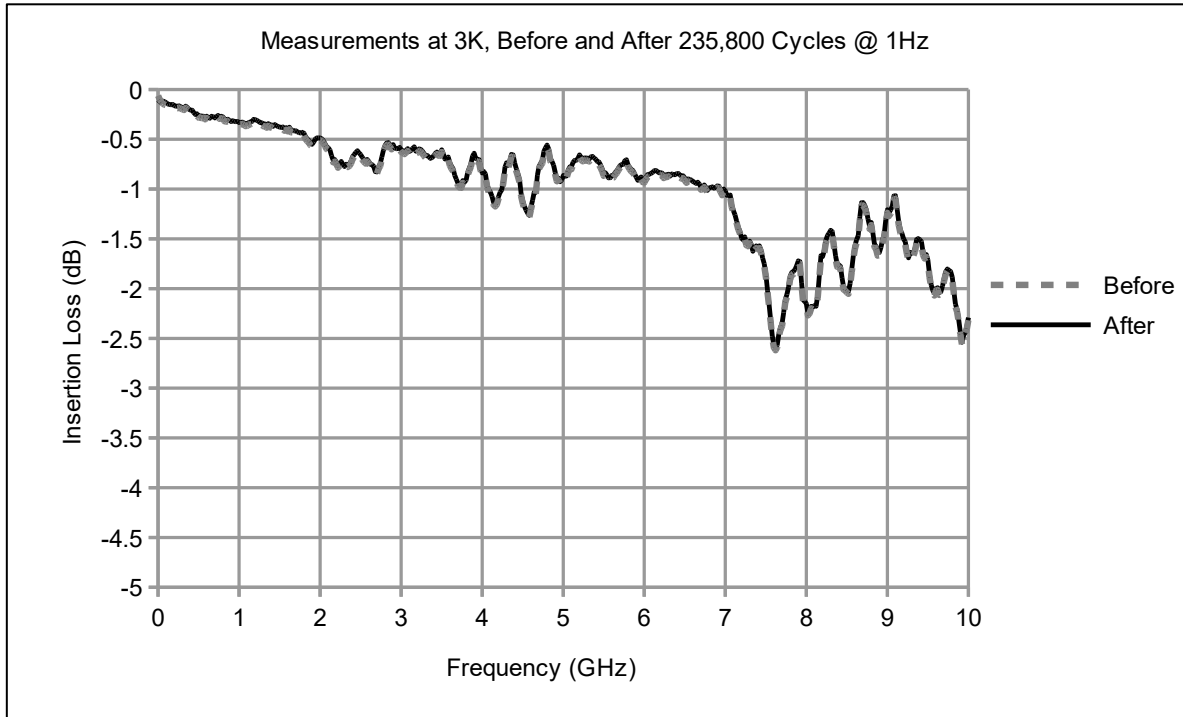

Insertion Loss Difference

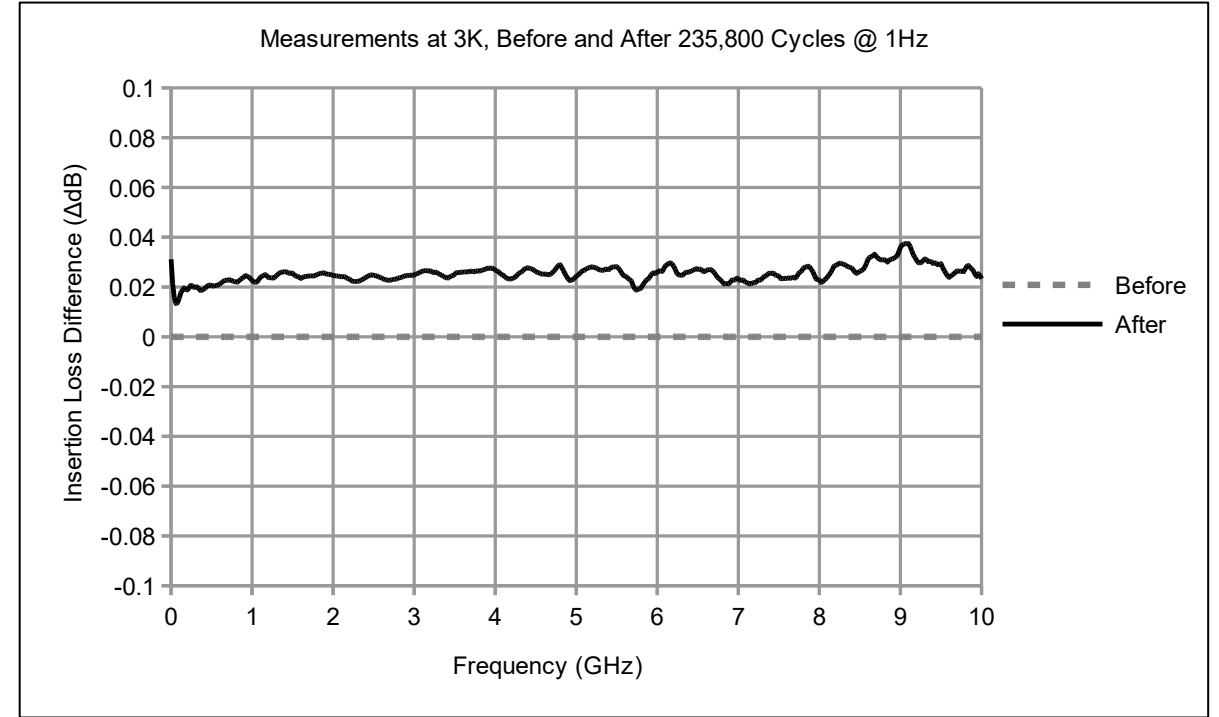

MM4250 offers dramatic throughput improvements

NO HEATING from Ideal Switch means NO WAITING for the dilution fridge to cool back to base.

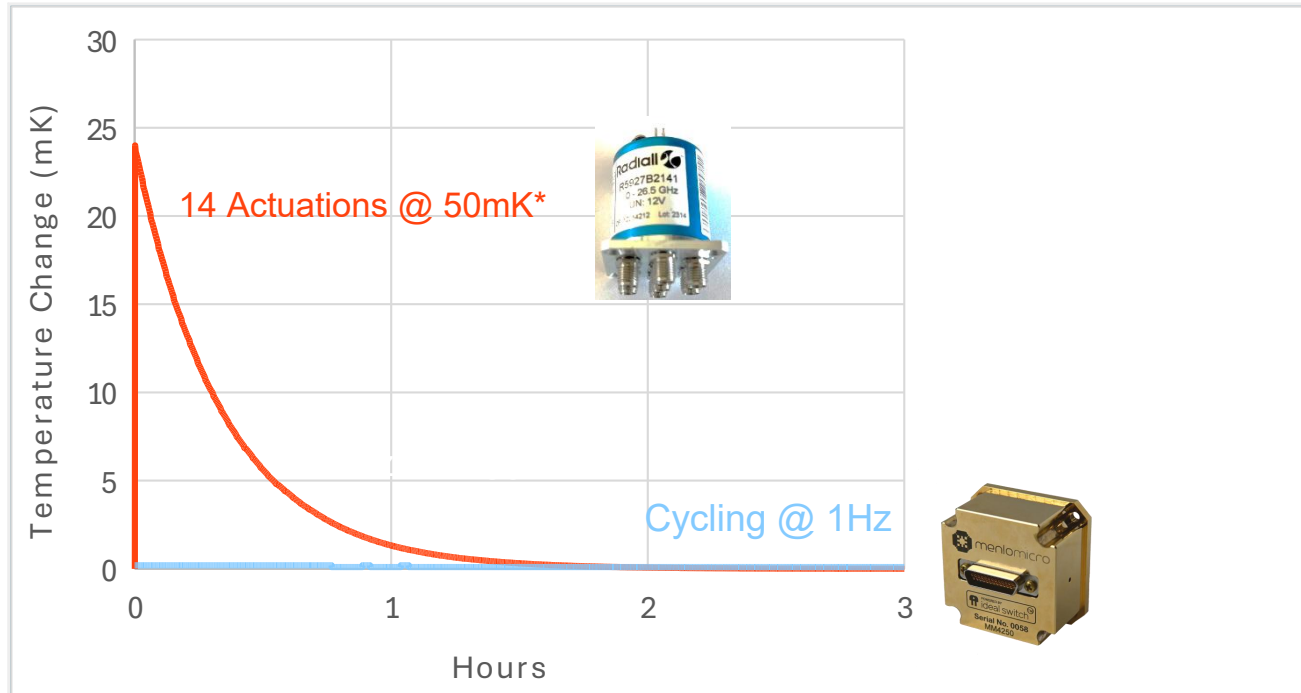

* [Technology Guide for Cryogenic RF Switches](#)

- *Traditional mechanical relays* increase the temperature in the fridge by *20 mK or more*, leading to hours of delays to test multiple channels.
- Menlo's Ideal Switch actuation is electrostatic requiring **less than 1 microwatt of power** to actuate the switches, compared to standard cryo switch generating a few Watts.
- Opening and closing the switch at any cycle rate causes **no measurable temperature increase** when operating at mK temperatures.
- This substantially increases throughput for device test and calibration!
- **SAVES HOURS IN DEVICE TEST/CALIBRATION**

Traditional Dilution Refrigerator Test System

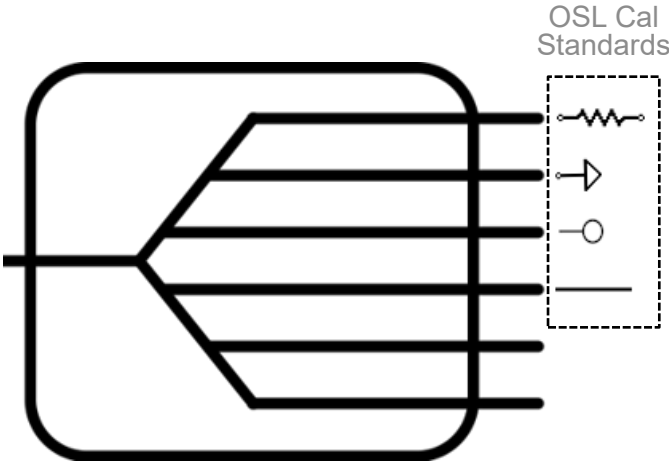
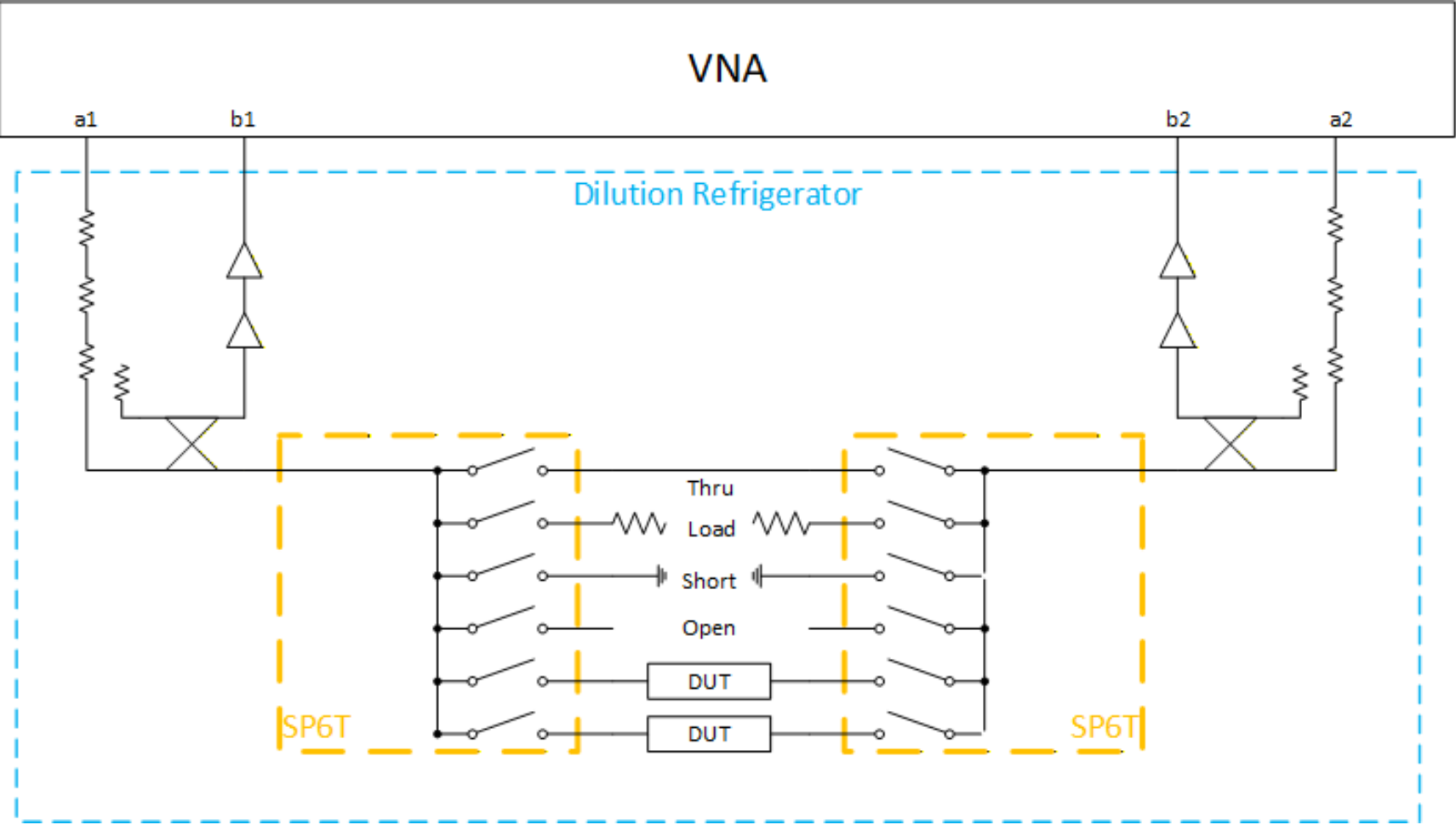

Built-in Internal RF Calibration Standards

- The MM4250 is designed with built in RF Calibration standards (OSL) to allow users to transfer RF calibration plane to connector outputs *without consuming RF Channels for calibration.*

- This provides **more available channels for DUTs** measurements.

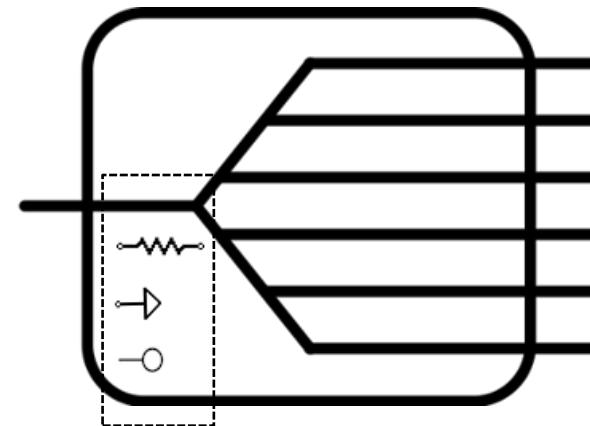
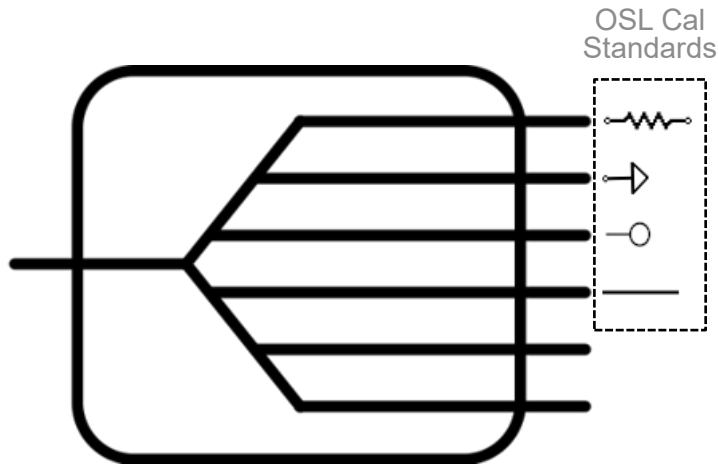

MM4250 Dilution Refrigerator Test System

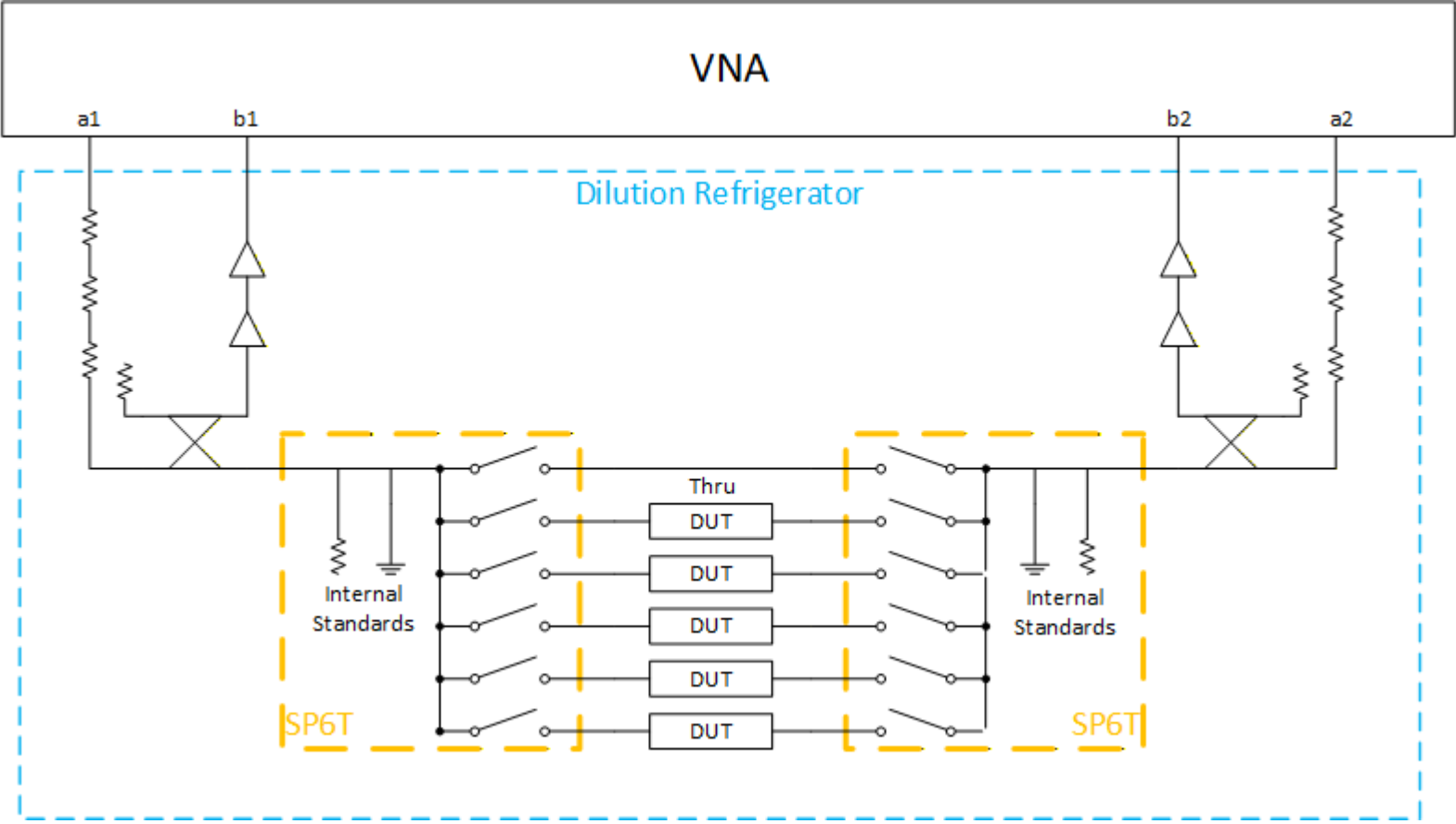

Built-in internal RF Calibration Standards provides **more available channels for DUTs** measurements.

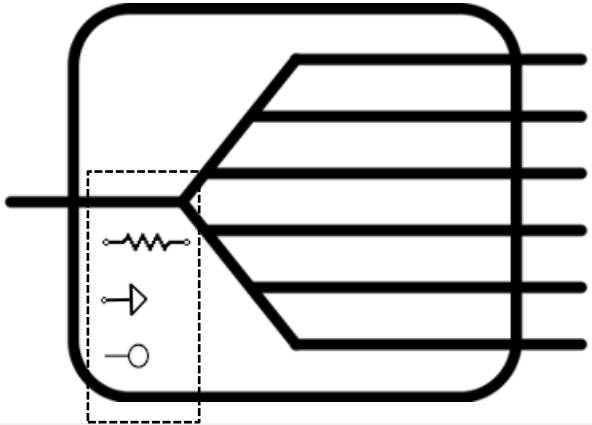

Internal Cal Standards

Menlo MM4250 Internal Cal Standards Validation 3K 6x6 calibration

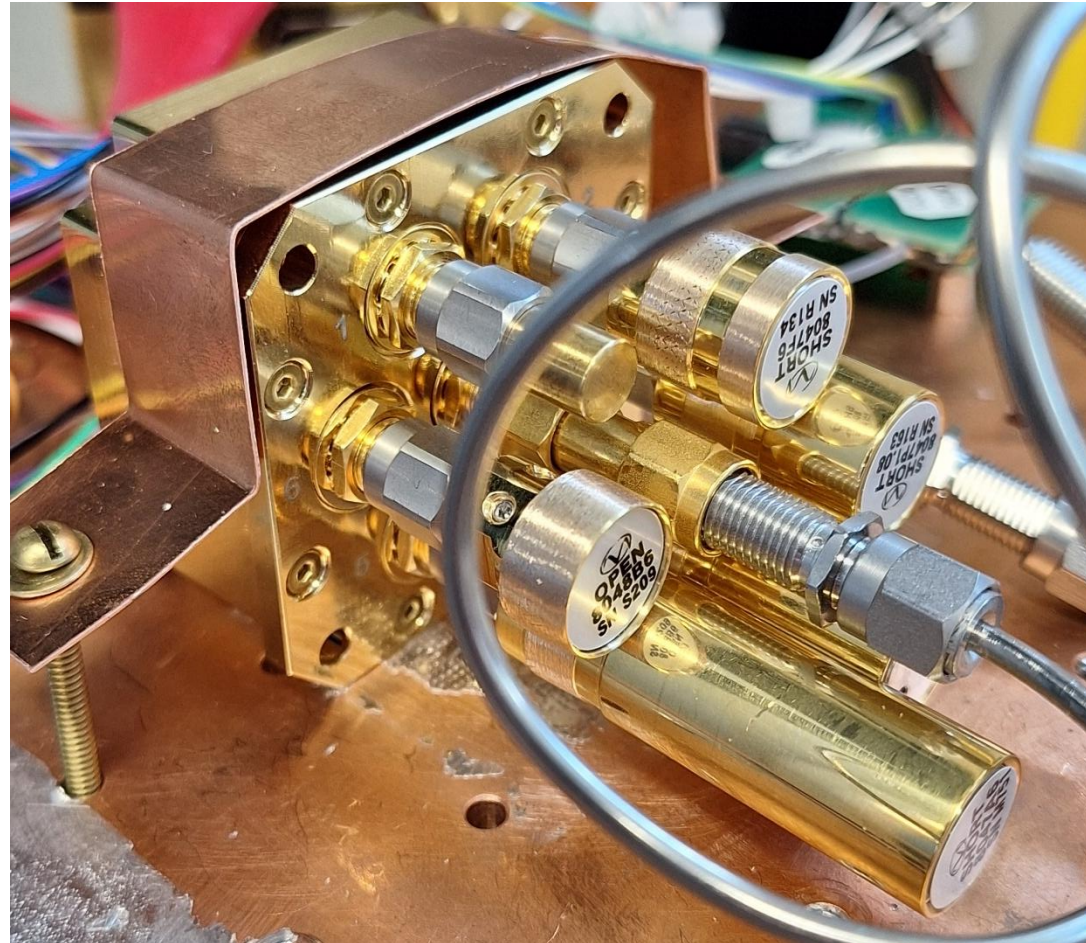
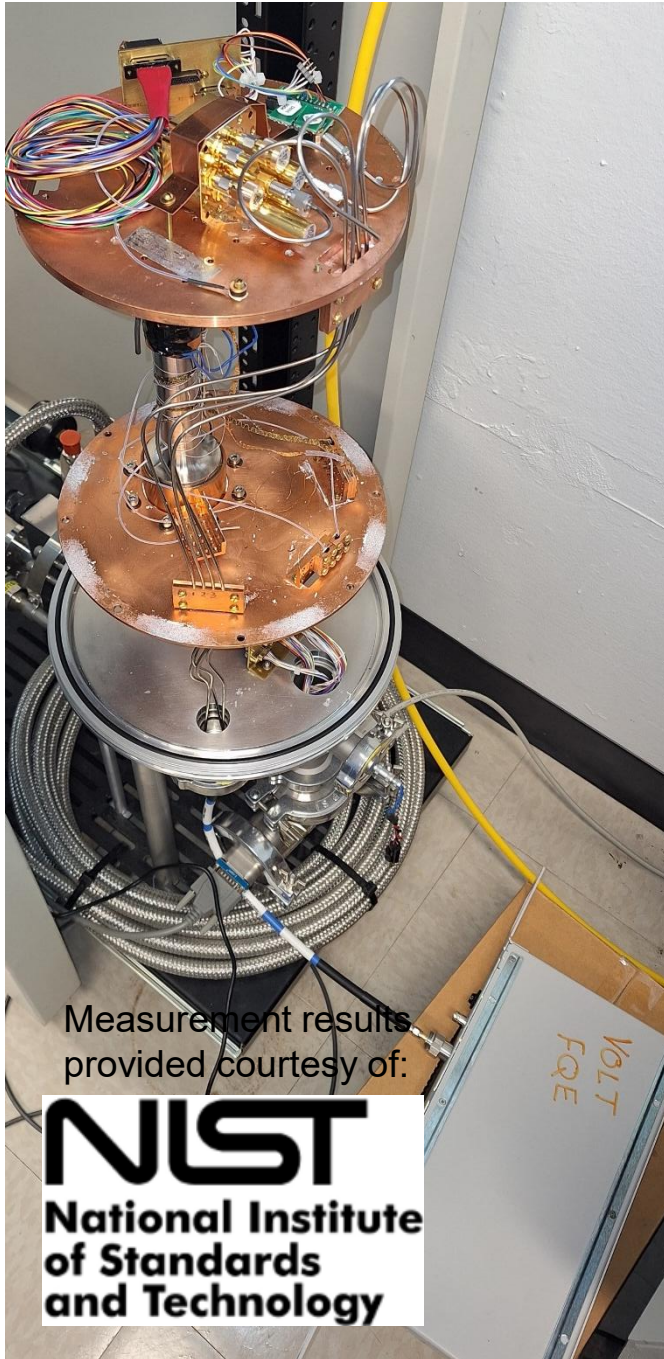

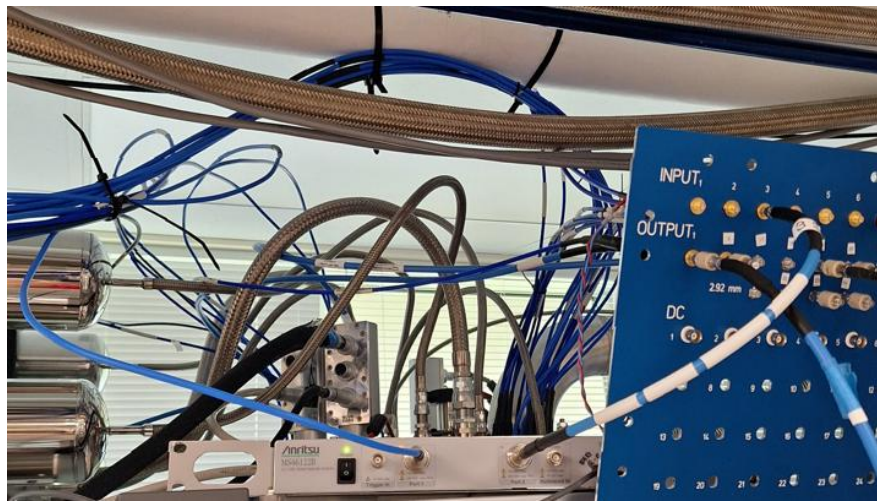

Dilution Refrigerator Tests

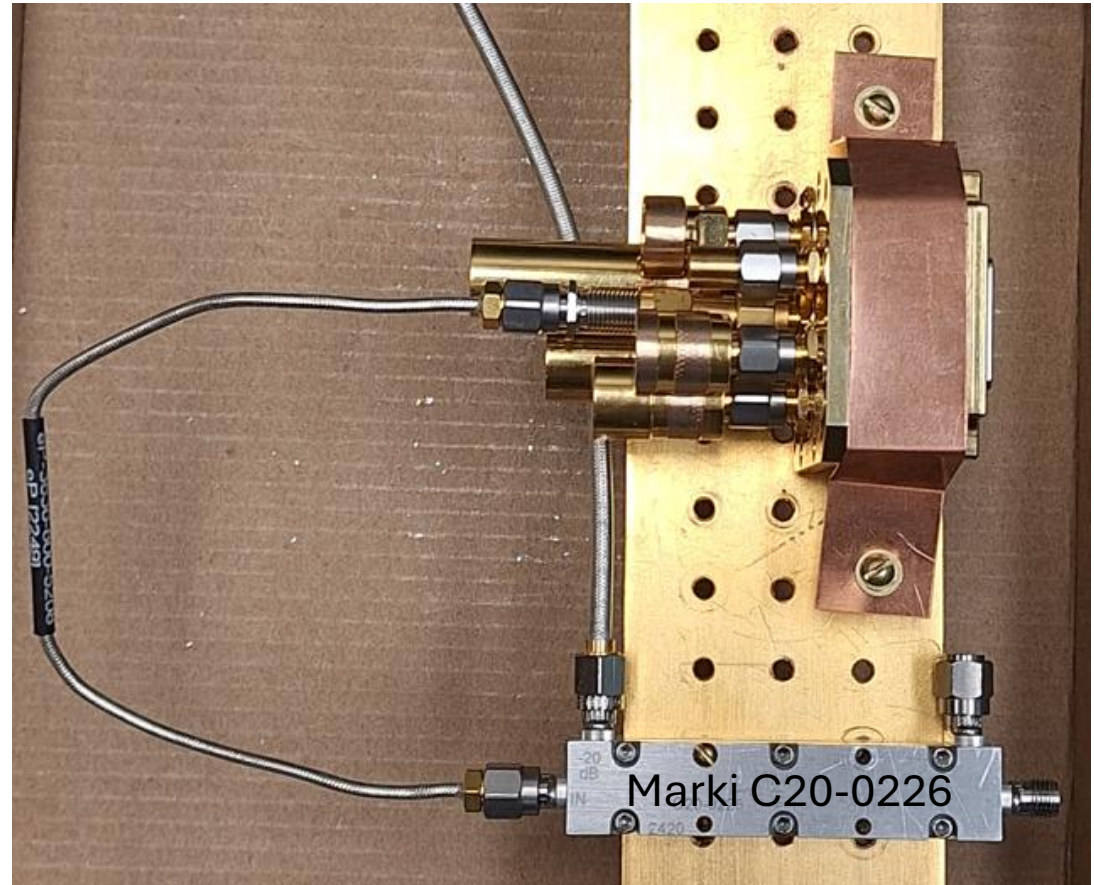

A**B****C****D****E****F**

	cooldown A	cooldown B	cooldown C	cooldown D	cooldown E	cooldown F
port1	port1_MOS1.s1p	port1_MOS6.s1p	port1_MOS5.s1p	port1_MOS4.s1p	port1_MOS3.s1p	port1_MOS2.s1p
port2	port2_MOS2.s1p	port2_MOS1.s1p	port2_MOS6.s1p	port2_MOS5.s1p	port2_MOS4.s1p	port2_MOS3.s1p
port3	port3_MOS3.s1p	port3_MOS2.s1p	port3_MOS1.s1p	port3_MOS6.s1p	port3_MOS5.s1p	port3_MOS4.s1p
port4	port4_MOS4.s1p	port4_MOS3.s1p	port4_MOS2.s1p	port4_MOS1.s1p	port4_MOS6.s1p	port4_MOS5.s1p
port5	port5_MOS5.s1p	port5_MOS4.s1p	port5_MOS3.s1p	port5_MOS2.s1p	port5_MOS1.s1p	port5_MOS6.s1p
port6	port6_MOS6.s1p	port6_MOS5.s1p	port6_MOS4.s1p	port6_MOS3.s1p	port6_MOS2.s1p	port6_MOS1.s1p
ecal_short	ecal_short_A.s1p	ecal_short_B.s1p	ecal_short_C.s1p	ecal_short_D.s1p	ecal_short_E.s1p	ecal_short_F.s1p
ecal_open	ecal_open_A.s1p	ecal_open_B.s1p	ecal_open_C.s1p	ecal_open_D.s1p	ecal_open_E.s1p	ecal_open_F.s1p
ecal_load	ecal_load_A.s1p	ecal_load_B.s1p	ecal_load_C.s1p	ecal_load_D.s1p	ecal_load_E.s1p	ecal_load_F.s1p
tier1	tier1_A.vnauncert	tier1_B.vnauncert	tier1_C.vnauncert	tier1_D.vnauncert	tier1_E.vnauncert	tier1_F.vnauncert

6 cooldowns
6 ports
6 standards

Standard/DUT	Notes
MOS1	Maury Flat short 360B 834047
MOS2	Maury offset short 8047F6 833986 SN: R134 5.0038 mm/0.1970"
MOS3	Maury offset short 8047P1.08 834105 SN: R163 10.795mm/0.425"
MOS4	Maury offset short 8047P1.8 834106 SN: R164 17.9832mm/0.708"
MOS5	Maury offset short 8047A6 816648 SN: M751 29.97963 mm/1.1803"
MOS6	Maury Open 8048B6 838985 SN:S209

All 6 x 9 = 54 traces recorded at both 3 K and 295 K

Plus one temperature sweep between base and room temp

All 6 positions, 295 K

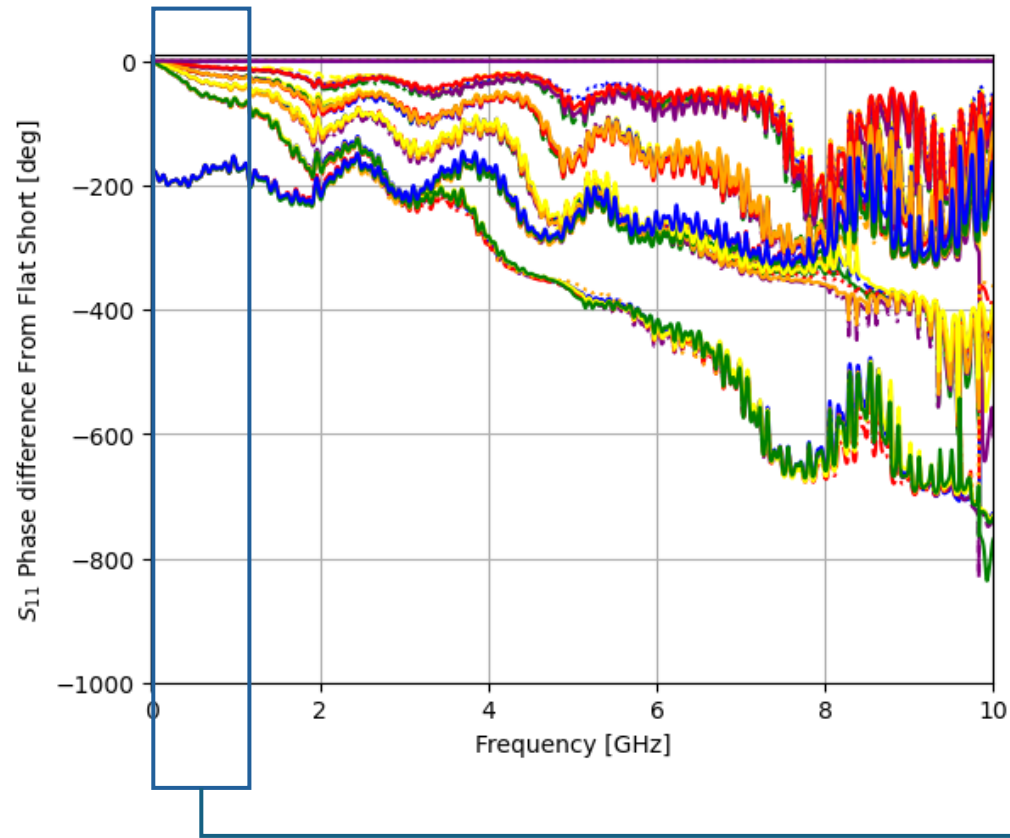

Same data, zoom to 1GHz

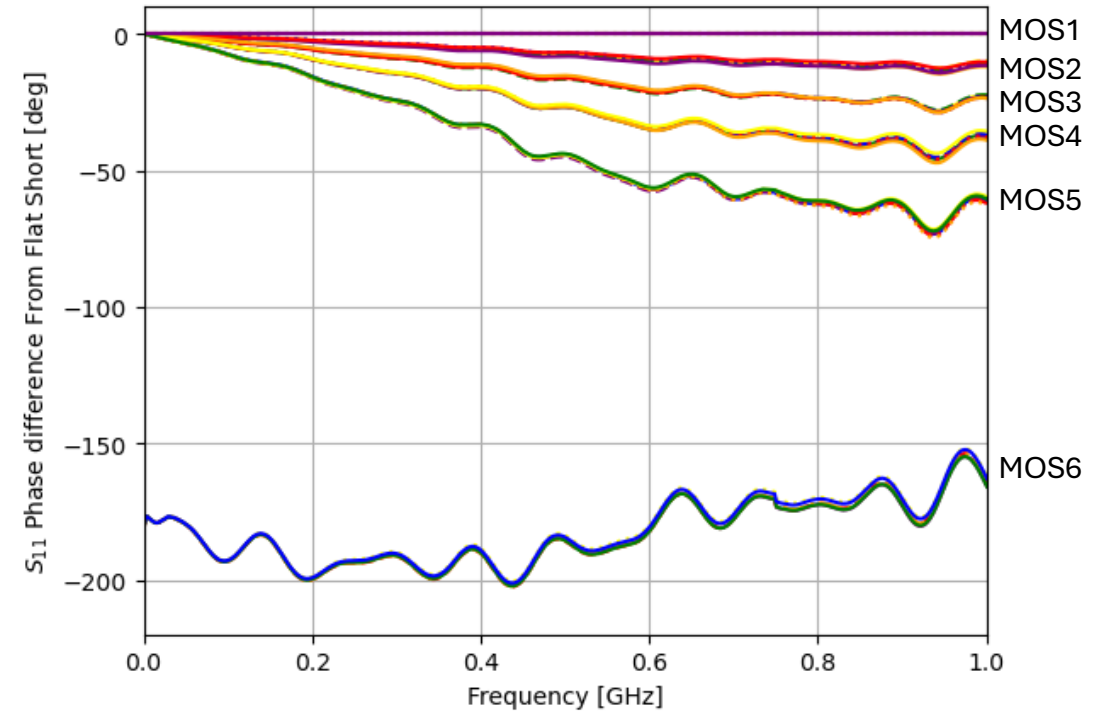

- Each group of lines represents a measurement of the phase change between MOS1 and MOS_x
- Grouped lines are each standard, showing variation across all 6 channels on MM4250

Built-in Internal RF Calibration Standards

Received 5 November 2022; revised ; accepted ; date of current version .
Digital Object Identifier 10.1109/JMW.20XX.0000000

Cryogenic RF MEMS Switch with Electronic Calibration Capability

Lafe F. Spietz¹, Chris Giovannello², Brandon Takaki², Wei Ye³, Beverly Boiko⁴,
Christian Long¹, Nathan E. Flowers-Jacobs¹, Adam J. Sirois¹, Peter F. Hopkins¹, Samuel P.
Benz¹, Dylan Williams¹ (Life Fellow, IEEE)

¹National Institute of Standards and Technology, Boulder, CO 80305, USA
²Menlo Microsystems, Inc., Irvine, CA 92618-3768, USA
³ETLinX Systems, LLC, Chelmsford, MA 01824, USA
⁴Form Factor, Boulder, CO 80301, USA

CORRESPONDING AUTHOR: D. Williams (e-mail: dylan@ieee.org).

ABSTRACT We characterize a cryogenic radio-frequency micro-electro-mechanical-systems single-pole-six-throw switch to 10 GHz. We test the switch from room temperature to milliKelvin temperatures. The switch contains an internal electronic calibration capability suitable for performing vector network analysis at room temperature and cryogenic temperatures. We demonstrate two calibration types, the first designed for measuring the scattering parameters of microwave devices connectorized with 3.5 mm coaxial connectors and the second for measuring the scattering parameters of microwave devices connectorized with Sub-Miniature version A (SMA) connectors.

INDEX TERMS Cryogenic measurement, electronic calibration, micro-electro-mechanical-systems, radio frequency, vector network analysis.

This work is licensed under a Creative Commons Attribution 4.0 License. For more information, see <https://creativecommons.org/licenses/by/4.0/>

VOLUME X, NO. X, MONTH 20XX

I. INTRODUCTION

We describe the calibration and characterization of a cryogenic coaxial radio-frequency (RF) micro-electro-mechanical-systems (MEMS) single-pole-six-throw (SP6T) switch from 10 GHz and from room temperature to milliKelvin temperatures.¹ We also calibrate and test an internal electronic calibration capability integrated into the switch that greatly simplifies calibrating vector network analyzers (VNAs) at the switch's output ports, especially at cryogenic temperatures. Finally, we develop two calibration types for the switch, the first designed for measuring the scattering parameters of devices under test (DUTs) connectorized with 3.5 mm coaxial connectors and the second for measuring the scattering parameters of DUTs connectorized with Sub-Miniature version A (SMA) connectors.

The first system for performing calibrated two-port vector scattering parameters at milliKelvin temperatures was reported by Ranzani, *et al.*, in [1]. Ranzani, *et al.* described a thru-reflect-line (TRL) calibration approach in coaxial transmission lines based on electromechanical coaxial switches. The switches allowed for routing signals from the VNA to coaxial calibration standards and to a coaxial DUT. Ranzani, *et al.* applied their approach to the development and characterization of connectorized circuits in [2, 3]. Similar approaches have been used since by Yeh, *et al.* [4], Oates, *et al.* [5] and others [6, 7]. More recently, Stanley, *et al.* [8, 9] and Celep, *et al.* [10] have introduced traceable coaxial calibrations at milliKelvin temperatures.

However, these approaches to performing calibrated scattering-parameter measurements in coaxial media suffer from several deficiencies at cryogenic temperatures. They are based on electro-mechanical switches that are slow compared to many other technologies, sometimes generate electrical pulses at their outputs that can destroy sensitive amplifiers used in performing network analysis at milliKelvin temperatures and can generate enough heat to be significant at milliKelvin temperatures (although some significant progress has been made to improve the switching efficiency of electro-mechanical switches at cryogenic temperatures [11]). They also often use difficult-to-characterize flexible cables to connect calibration standards and DUTs to the switch and rely on symmetry in the switches and flexible cables to obtain accurate calibrations.

In this work, we calibrate and characterize a novel Menlo Microsystems² MM4250 SP6T RF coaxial switch based on their Ideal Switch[®] technology, which is a MEMS process technology. The MM4250 is designed to be a direct replacement for RF electro-mechanical switches currently in use at cryogenic temperatures.

The internal electronic calibration capability of the MM4250 switch greatly simplifies calibrations for the user. Unlike a standard electronic calibration unit [12, 13], which would calibrate a VNA to the switch's input port, we set the calibration reference planes in our experiments to the output ports of the switch. This allows use of the MM4250's internal electronic calibration standards to calibrate a VNA connected to the input port of the switch to any of the switch's six output ports over a wide range of temperatures with a calibration adapted to

¹ We use this term to mean less than 50 mK.

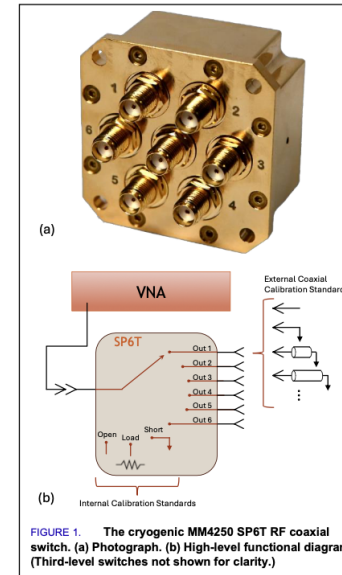

FIGURE 1. The cryogenic MM4250 SP6T RF coaxial switch. (a) Photograph. (b) High-level functional diagram. (Third-level switches not shown for clarity.)

characterizing either 3.5 mm-connectorized DUTs or SMA-connectorized DUTs.

II. CRYOGENIC SP6T RF SWITCH

Figure 1 shows a photograph and high-level functional block diagram of the MM4250 RF switch that we characterized. The switch's SMA input port can be seen in the center of the switch face surrounded by its six SMA output ports near the periphery of the switch.

The switch was designed to have an RF 3 dB bandwidth of approximately 8 GHz and is built using a series of Menlo Micro SP4T RF MEMS switches arranged in three levels. The first level consists of a single switch, which is used to select between either a) a set of internally selectable open, short and load calibration standards or b) allowing the signal to pass through to the second switching level, which selects between the main RF measurement paths.

The second-level SP4T switches fan out to the six output paths. The design employs a special mode on the Menlo Micro RF switches called "super-port mode", which greatly improves return loss and insertion loss for applications requiring many

² We use brand names only to clarify the experimental configuration. The National Institute of Standards and Technology does not endorse commercial products. Other products may work as well or better.
VOLUME X, NO. X, MONTH 20XX

📄 Paper summarizes the characterization of the MM4250 internal standards and associated measurement uncertainty

📄 Can be viewed/downloaded here:

📄 <https://menlomicro.com/newsroom/cryogenic-rf-mems-switch-with-electronic-calibration-capability>



Webinar for Internal Calibration Standards

Check out this webinar that describes MM4250's new calibration methodology described in the NIST paper.

[RF Calibration at Cryogenic Temperatures: A New Measurement Paradigm for Quantum Technologies | FormFactor, Inc.](#)

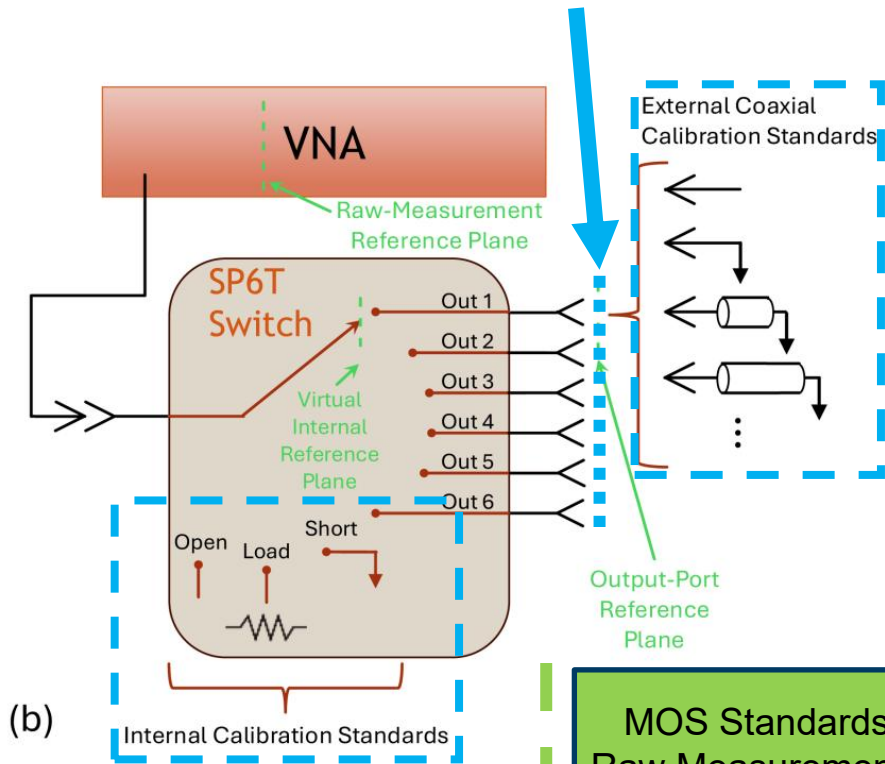

(b)

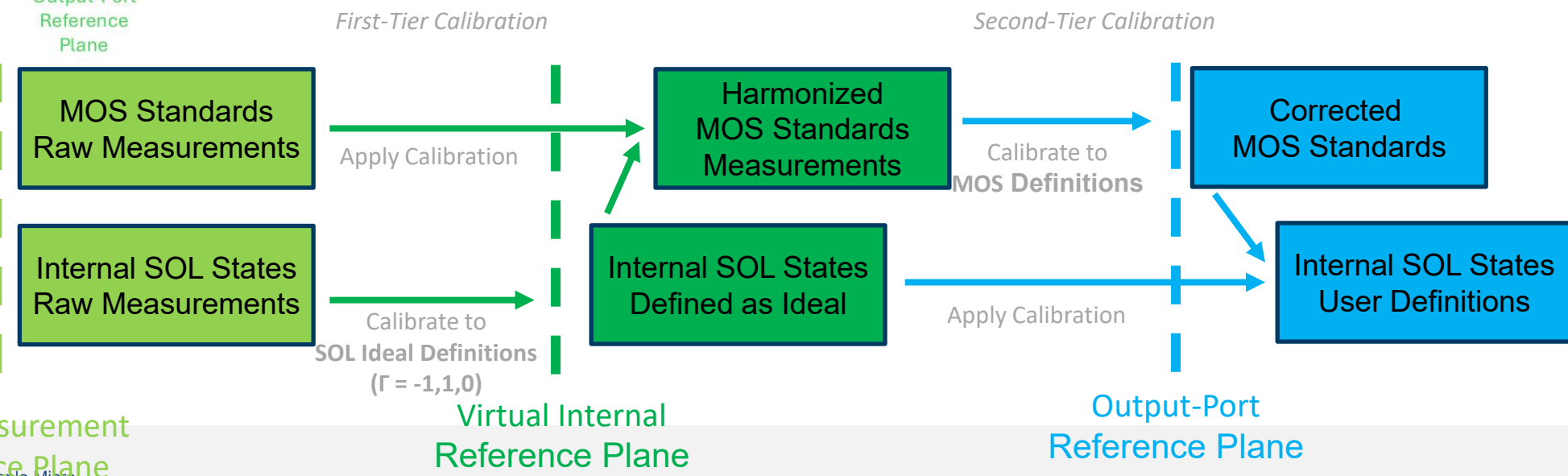

USB HiV Driver Board

Controlling MM4250

- ❖ The MM4250 requires 90V to be supplied to the Micro-D connector pins to actuate the channels of the device.
- ❖ The USB HiV driver board is for controlling one or multiple MM4250 devices.
- ❖ By connecting the driver board to a computer via USB, the user can control one or both Micro-D Male 25p connectors to be able to synchronously control one or two MM4250s at once.
- ❖ The board can be control manually with an installable PC application or programed via API.

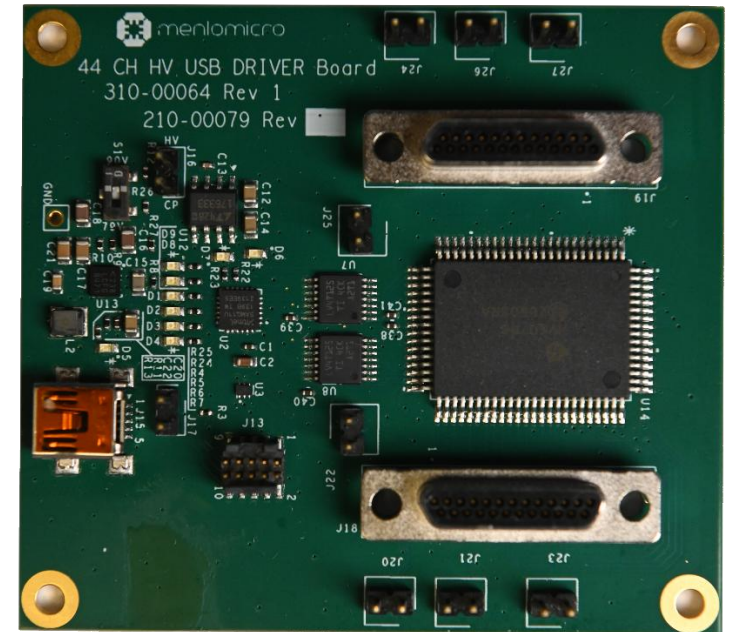

Micro-D Connector Configurations

- The MM4250 and Driver Board use Micro-D 25p connectors for device control.
- If the inside of your system has a:
 - Micro-D **Plug**: Connect to the MM4250 with a **plug-to-socket** cable assembly.
 - Micro-D **Socket**: Connect to the MM4250 with a **plug-to-plug** cable assembly

USB Driver Board
Male/Plug



MM4250
Female/Socket



MM4250-KIT1-ENG

Contents

- (2) SP6T RF Switch Module for cryogenic applications
 - (1) USB HiV Driver Board
 - (1) Micro-D 25P, Split Male to Female Cable Assembly
 - We offer a split Male to single Female cable assembly for connecting two MM4250s to the same DC control source.
- Please contact sales@menlomicro.com for inquiries.



Ideal Switch for Quantum Computing Roadmap

- Menlo is looking to push in two directions to continue to enable the RF densification needs of the growing quantum computing market:

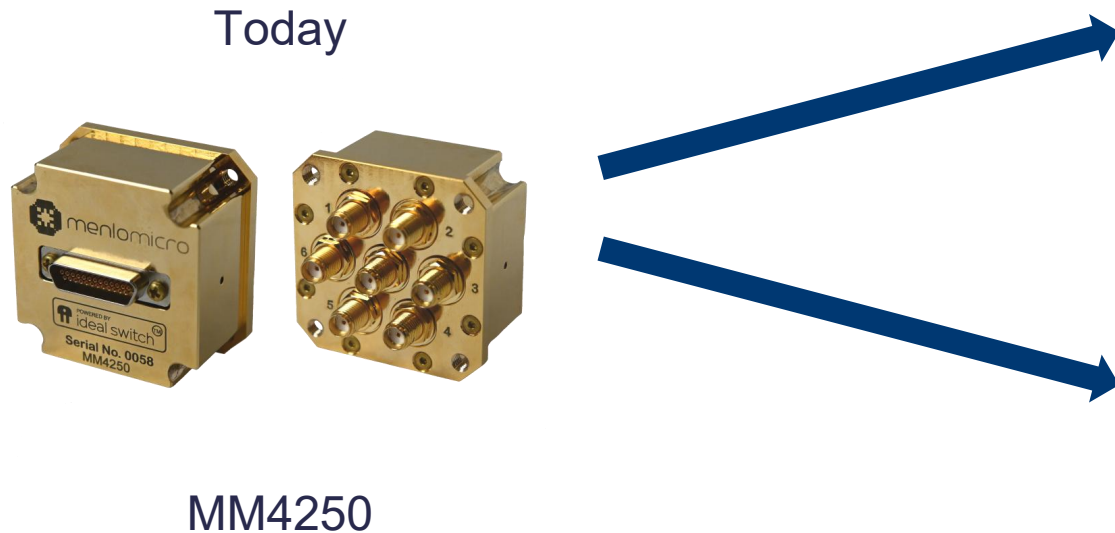

Enhanced device packaging technology,
optimized for cryogenic operation

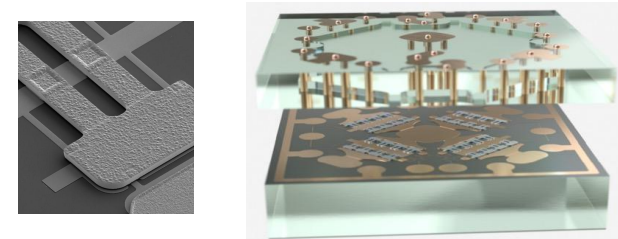

Increased RF densification using higher
frequency RF switches and higher density
connectors
SP16T, SP32T and beyond



Thank you.