

**PRODUCT BRIEF**

# MM5130

## 26 GHz SP4T RF Switch

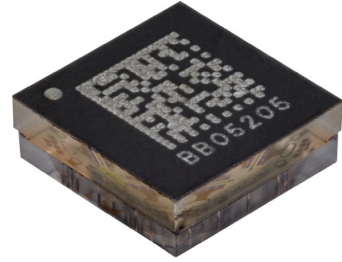

The MM5130 device is a high-power SP4T micro-mechanical switch offered by Menlo Micro. Menlo Micro has developed a new Ideal Switch® fabrication process and applied it to DC and wideband RF/microwave switch applications.

This innovative technology enables highly reliable switches capable of 25 W forward power. The MM5130 provides ultra-low insertion loss and superior linearity as an SP4T from DC to 18 GHz, and greater than 3 billion switching cycles.

The MM5130 can also be configured in SuperPort mode that extends the frequency operation to 26 GHz. The MM5130 is an ideal solution for replacing large RF electromechanical relays, as well as RF/microwave solid-state switches in applications where linearity and insertion loss are critical parameters. The four switch channels are individually controllable by applying a gate voltage to the corresponding RF GATE pin.

### **FEATURES**

- DC to 26 GHz Frequency Range
- 25 W (CW), 150 W (Pulsed) Max Power Handling
- Low On-State Insertion Loss: 0.3 dB @ 6.0 GHz
- High Linearity, IIP3 95 dBm Typical
- 25dB Isolation @ 6.0 GHz/ 45 dB Super-Port Mode
- High Reliability > 3.0 x 10<sup>9</sup> Switching Operations
- 2.5 mm x 2.5 mm WLCSP Package

### **APPLICATIONS**

- Switched Filter Banks and Tunable Filters
- High Power RF Front Ends
- Antenna Tuning
- Low-Loss Switch Matrices & EM Relay Replacement

### **MARKETS**

- Defense and Aerospace
- Test and Measurement Systems
- Wireless Infrastructure
- Medical Equipment

**FIG. 1** Wafer Level Chip Scale Package



**FIG. 2** Functional Block Diagram

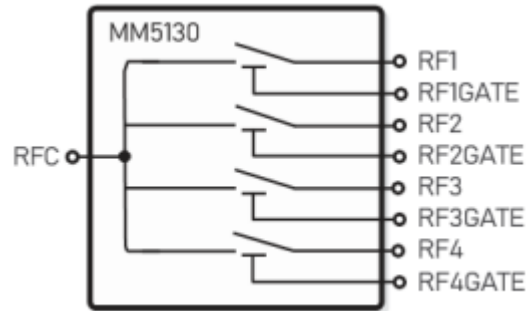

**FIG. 3** MM5130

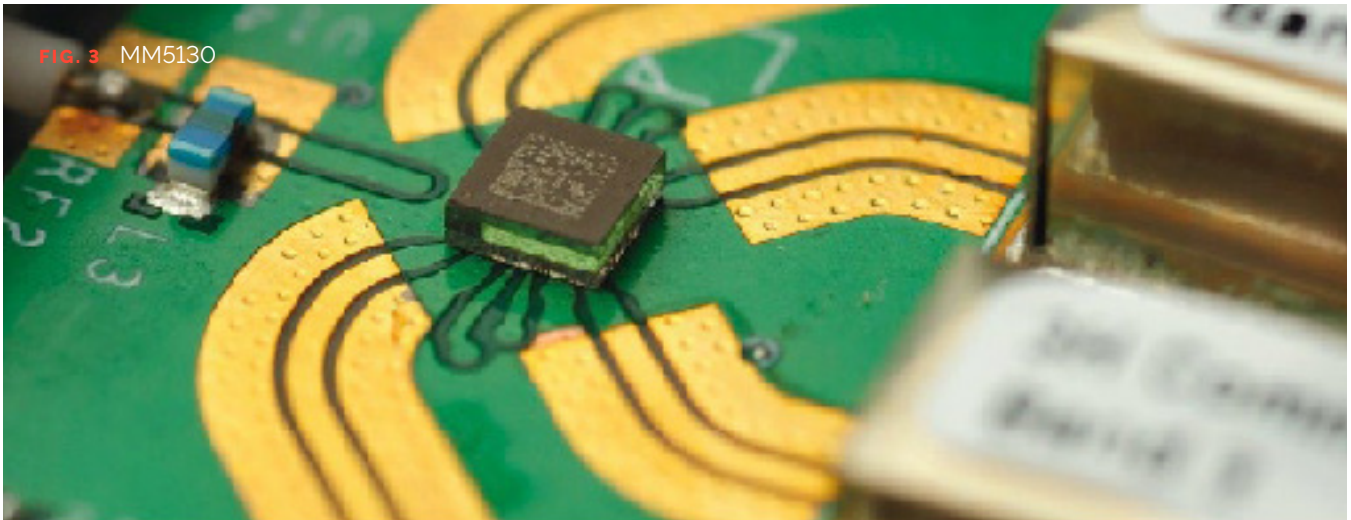

**FIG. 4** MM5130 IL vs. Frequency over Temp

