



Application Note

Avoiding Floating Nodes in Ohmic MEMS Circuits

AN-0002

August 2022

Controlling DC Potential in Ohmic MEMS Circuits

Ohmic MEMS circuits are generally sensitive to *hot-switching* a voltage across the switch contacts when transitioning between open and closed states. When designing switching circuits with MEMS, it is important to avoid hot-switching which can degrade operational lifetime. This implies that the differential DC voltage across the switch INPUT-OUTPUT terminals should be near zero volts when the switch opens or closes. Though the terminal DC voltage when switching is recommended to be 0 V, the requirement is that the voltage level is equal on both sides of the switch when it opens or closes. To maximize the lifetime of MEMS devices, hot-switching should be avoided. This application note describes how to avoid hot-switching arising from a build-up of charge in DC-isolated floating nodes.

Methods to Avoid Floating Nodes

There are several ways to avoid the floating node issue. In order of preference, they are:

1. Design the circuit to have a DC-path to ground through the system so that there are no DC-isolated floating nodes. This is the preferred way as it does not impact Q-value of the circuit nor the DC-isolation properties. Isolate system input and output so that no DC voltage is entering the MEMS network.
2. In RF applications, if one or several floating nodes are necessary to achieve desired circuit topology, use of large value inductors to GND to connect otherwise DC-isolated nodes should be considered. The Inductor will provide a DC path to ground while blocking the path for RF signal. This may be an option for higher frequency applications (in the GHz range) where a large value (large reactance) inductor is reasonable small.
3. For lower frequency applications where inductors are impractical due to physical size, it is recommended to use a large value resistor between the floating node and ground. This ensures that any charge that accumulates over time has a way to discharge. If the system cannot be designed without floating nodes, and the frequency is too low to use inductors, then this method using “pull-down” resistors is recommended. Recommended values are 100 k Ω to 10 M Ω .

Node Impedance and Loading on High-Q Circuits and Resonators

In systems with many MEMS switches, resistive losses can add up and it may be desirable to use the method that provides the least amount of loading on the node, especially if the floating node is a high impedance point such as a filter resonator. Note that only one method for DC-grounding per network node is required.

For RF circuits with high Q values such as resonators, resistor values at the upper end of the range are recommended. Likewise, for circuits where DC-leakage is critical, again resistor values at the upper end of the range are recommended.

A Design Example

Figure 1 below shows an RF application using MM31xx with an L-C network and two floating nodes (with the switches open). Apart from possible overvoltage due to stored charge on the isolated nodes, the switch on the left has an output that is DC isolated. Since the Output is also the reference for the Gate voltage, this will lead to problems with actuation and de-actuation of the switch. The switch on the right side has its Output DC-grounded so no action is required there, but the Input is DC-isolated.

To remedy the situation and fix these DC-isolated floating nodes, Figure 2 shows how 10 M Ω resistors have been added to connect the floating nodes to ground. With the Output of the switch on the right side now at ground potential, the switch will actuate and de-actuate as intended. Any charges that accumulate will discharge safely to ground and the switches are safe to operate.

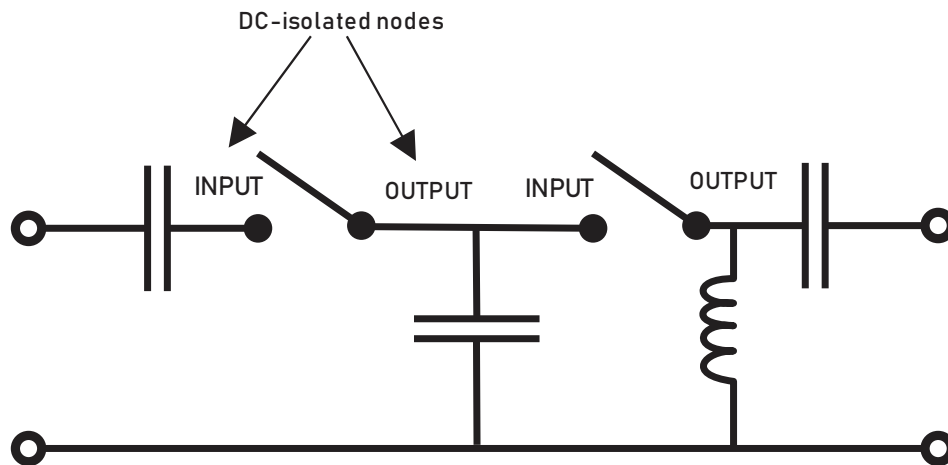

Figure 1: Switch L-C Network with Two DC-Isolated Floating Nodes

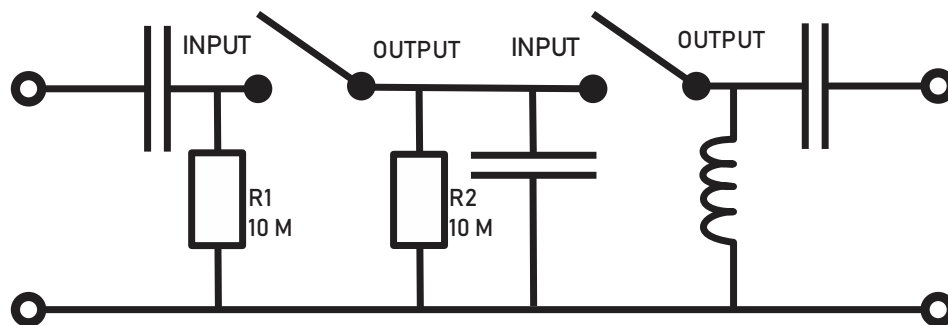

Figure 2: L-C Network from Figure 1 with Added Resistors Eliminates the Isolated Nodes



Super-Port Considerations

Super-Port connection method can provide enhanced performance in RF isolation and return loss. The floating node arising from the series connection of switches together in Super-Port can be avoided by using a shunt with DC path to ground and sequenced switching. Figure 3 below shows a Super-Port connection example using a MM5130 with R switched ON creating a DC path to ground when the Super-Port switch is Off. The R is removed when the Super-Port switch is On.

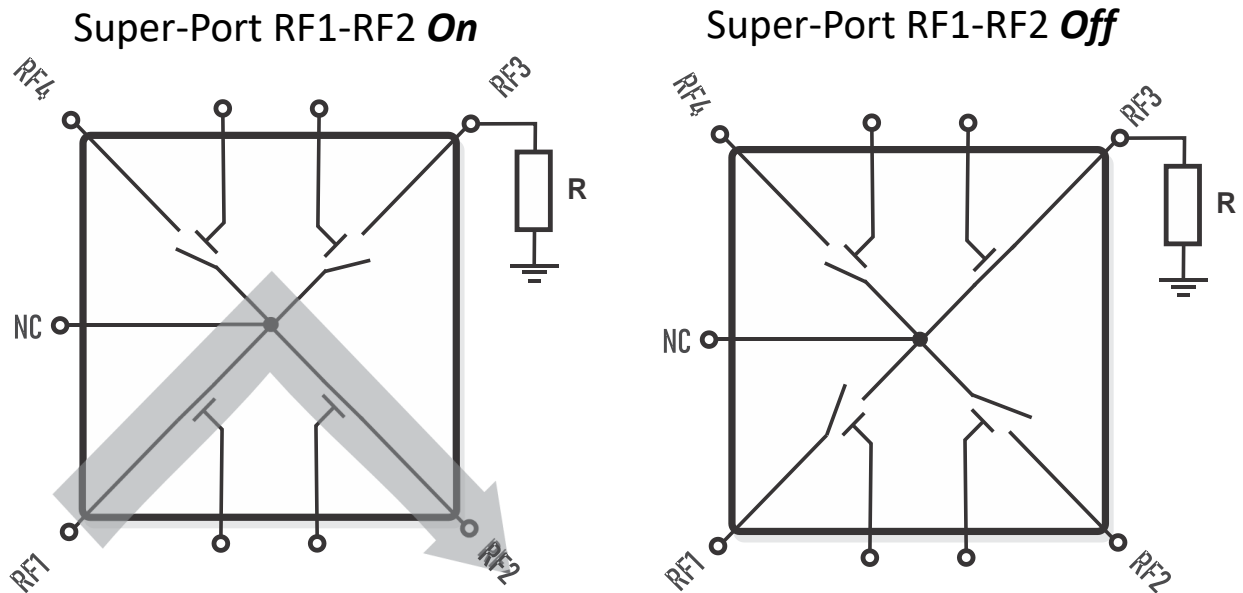

Figure 3: Super-Port Connection with Sequenced Switching of DC path to Avoid Floating Node

Sequencing the gates as shown in Figure 4 below provides a solution to removing the DC path when the Super-Port is ON. The DC path through RF3 is ON when the Super-Port switch path is OFF thereby avoiding the floating node arising at the series connection of RF1 and RF2.



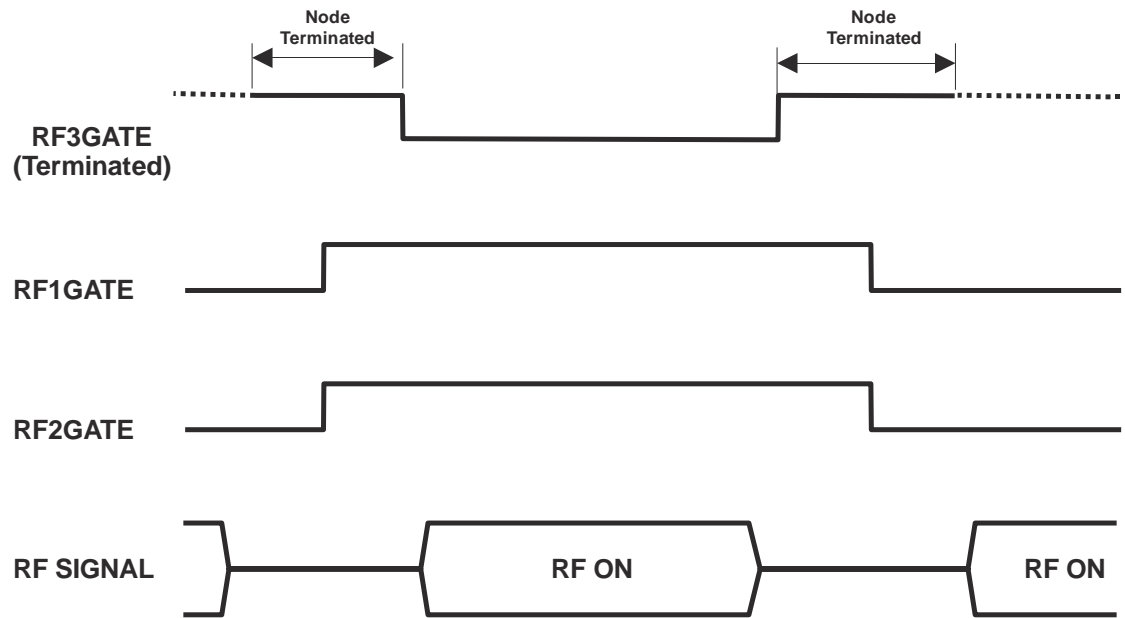

Figure 4: Super-Port gate sequencing disconnects DC path when switch is ON

Important Information

Disclaimer

The data presented in this document is for informational purposes for engineering samples, which have not yet been qualified for production. It shall in no event be regarded as a guarantee of final specifications or characteristics. Any warranty or license for this product shall be specified and governed by the terms of a separate purchase agreement. Menlo Micro does not assume any liability arising out of the application or use of this product; neither does it convey any license under its patent rights, nor the rights of others.

Menlo Micro reserves the right to make changes in these specifications and features shown herein to improve reliability, function and design, or discontinue of this product, at any time without notice or obligation. Contact our product representative for the most current information.

Warning

This product is not authorized for use:

- In any life support systems.
- Applications for implanting into the human body, without the express written approval from Menlo Micro.

Trademark Notices

All trademarks and product service marks are owned by Menlo Microsystems, Inc.

Contact Information

Please contact Menlo Micro for the latest specifications, additional product information, test and evaluation boards, product samples, worldwide sales and distribution locations:

- **Internet:** www.menlomicro.com
- **E-mail:** sales@menlomicro.com

For product technical questions and application information: support@menlomicro.com.